

2021 CUSTOM GUITAR

DESIGN GUIDE



1960 STRATOCASTER® - JOURNEYMAN RELIC®
FADED AGED SURF GREEN - 9231012578



FOREWORD

A Fender Custom Shop instrument is extraordinary. You know it when you play one—it's definitely more than the sum of its parts. It's filled with intangible, electrifying elements that add a new dimension to your playing experience. It's as if the instrument itself is imbued with history, alive with the spirit of the place where it was built and the devotion of those who crafted it.

The Custom Shop is home to Fender's most skilled and talented builders. It's a bustling, noisy and creatively volcanic place that re-earns its nickname—the Dream Factory—every day. Custom Shop builders are completely dedicated to their art—part craftsman, part artist, part music fan and, more often than not, part mad scientist. They're the best at what they do, and they pour all of their passion, hard-earned knowledge and skill into every instrument they build. It's no ordinary place, and the creations that come from it are no ordinary instruments. Welcome to the Fender Custom Shop.

For players who wish to create a completely custom instrument—anything from a humbucking pickup-equipped banjo to a custom-engraved aluminum-bodied Strat®—we offer Masterbuilt, a singular experience working one-on-one with one of our Master Builders. Custom-Built is for those prefer to start with one of our time-honored models and personalize the specifications to meet your specific needs. Use this guide to design your very own Masterbuilt or Custom-Built Fender guitar and make your dreams come true.

©2021 Fender Musical Instruments Corporation. FENDER®, STRATOCASTER®, STRAT®, TELECASTER®, TELE®, PRECISION BASS®, P BASS®, Jazz Bass®, J Bass®, ESQUIRE®, Nocaster® and the distinctive headstock designs commonly found on Fender guitars are registered trademarks of FMIC. All rights reserved.

All other trademarks are the property of their respective owners.

All Fender Custom Shop instruments are expertly crafted according to exact order specifications and arrive free of defects. Those instruments not abiding by this policy will be repaired, modified or replaced by us at no cost to you. Consult your local retailer, distributor or the Custom Care™ website (customcare.fender.com) for details.

Fender Musical Instruments Corporation
17600 North Perimeter Drive
Scottsdale, AZ 85255-5440
T: (480) 596-9690
F: (480) 596-1384

fendercustomshop.com

All colors, features and specifications are subject to change without notice.

Photography by Mark Keraly ©FMIC



CONTENTS

Ordering Yours	5
Masterbuilt	7
Master Builders	8
Custom-Built	13
Base Models	15
Stratocaster Models	16
Telecaster Models	18
Precision Bass Models	20
Jazz Bass Models	21
Offset Models	22
Aging Styles	23
Tonewood Options	28
Body Wood	28
Neck Wood	30
Color Options	31
Neck Shapes	35
Fret Wire	39
Pickup Option	41
Wiring Option	45
Hardware Options	52
Design Guide Order Form	58

**HOW
TO**

USE THIS GUIDE

Is there a special Fender instrument that you have been dreaming of your whole life? We have some good news for you! The Fender Custom Shop can take your dreams and shape them into a tonal reality. The process is simple:

01 SELECT A BUILD LEVEL

Masterbuilt or Custom-built

02 SELECT A CUSTOM SHOP BASE MODEL

Choose from a wide range of guitars and basses

03 SELECT AN AGING PACKAGE**04 SELECT YOUR OPTIONS**

Choose your custom options from our extensive menu of offerings

05 ADDITIONAL NOTES

Use the "additional notes" section if your desired options are not listed

06 SUBMIT YOUR ORDER

Take this completed design guide to a Custom Shop Showcase Dealer which you can find at www.fendercustomshop.com/dealers/

01



BUILD LEVEL: MASTERBUILT

In every art form there are those who have mastered their craft so thoroughly, through years of training and experience, their work routinely commands extra acclaim and admiration, not to mention outright awe. These astonishing artisans are the Master Builders of the Fender Custom Shop; a select group of the most talented builders recognized around the world for their matchless skill, limitless imagination and utter devotion to their art.

Crafting a guitar with a Custom Shop Master Builder is the ultimate artistic partnership—simply put, no idea is too crazy and no job too large or too small. They'll walk you through everything—body design, neck shape, tonewoods, pickups, hardware and more—to give you the look, feel and sound that you're searching for. From start to finish the Master Builder will personally ensure that each guitar is built with the highest possible quality and to your exact specifications. Additionally, it's about more than just specifications, it's about making the instrument of your dreams a concrete reality.

MASTER BUILDERS

Imagine the greatest artists in history gathered under one roof; Michelangelo, DaVinci, Picasso and Dali working next to each other, sharing pigments, knowledge and expertise. The Fender Custom Shop is exactly that, the world's most esteemed luthiers gathered together to create peerless instruments that are astounding works of art—the Master Builders. They are known the world over for their skill and have built instruments for Jeff Beck, Ritchie Blackmore, Eric Clapton, Dick Dale, Mike Dirnt, Bob Dylan, Robben Ford, Buddy Guy, Merle Haggard, Reggie Hamilton, Mark Hoppus, John 5, Keith Richards, Sting and U2... just to name a few!



Paul Waller

PAUL WALLER

Paul Waller is a Southern California native with woodworking and luthiery in his blood. He built his first guitar at age 14 in his high school woodshop, joined a cabinet shop right out of high school and, after a stint at a small Southern California guitar maker, enrolled at the acclaimed Roberto-Venn School of Luthiery in Phoenix, from which he graduated in spring of 2000.

Waller joined Fender in 2003. He spent two years working closely with master archtop craftsman Bob Benedetto, and became steeped in the many facets of building techniques from all the Custom Shop's Master Builders. After an extensive seven-year apprenticeship, Waller became a Master Builder in 2010.

His Fender Custom Shop work includes bass guitars for U2's Adam Clayton, a custom Thinline Telecaster for U2 vocalist Bono, Telecaster guitars for the Rolling Stones' Keith Richards and co-work on a Stratocaster for fellow Stones guitarist Ronnie Wood, Stratocaster guitars for Buddy Guy, the Nile Rodgers "Hitmaker" Stratocaster, a custom double-neck Jazzmaster for Queens Of the Stone Age guitarist Troy Van Leeuwen, the George Harrison Tribute Rosewood Telecaster, and the George Harrison Rocky Stratocaster.

DALE WILSON



Dale Wilson

Dale Wilson arrived at Fender in 2003, joined the Custom Shop in 2005 and became a Master Builder in 2011. Building guitars has been a driving passion for the California native since childhood. "Ever since I can remember, I've always loved guitars," he said. "I didn't dream of being a rock star; I dreamt of building the ultimate guitar. I was equally enthralled with the guitars just as much as I was with the players."

Woodworking runs in the Wilson family, and the requisite Custom Shop zeal for outstanding craftsmanship has long been part of Dale's DNA. He did repair work and mods in a small guitar shop right out of high school in the late 1980s; subsequently, he moved on to stints at Dobro and Rickenbacker before arriving at Fender, where he worked on Guild, Gretsch and Benedetto guitars before beginning his apprenticeship with various Custom Shop Master Builders.

He enjoys calling upon his extensive and varied experience as a craftsman to create highly distinctive guitars such as the Resophonic Thinline Telecaster®. Wilson also built five beautiful custom guitars for the January 2011 NAMM Show while still an apprentice and was asked to signed the back of the headstocks, garnering him his Master Builder status.



JASON SMITH

A Custom Shop veteran and son of longtime Fender R&D legend Dan Smith, Jason Smith grew up on Fender — “It has always been in my family,” he said, “And I was always extremely interested in everything my father did.”

Born in Rochester, N.Y., and raised in California, Smith remembers meeting guitar greats from about age 5 on through his father’s work with Fender—Eric Clapton, Yngwie Malmsteen, Jeff Beck and Robben Ford, to name only a few. He went to his first big rock concert at age six—Rush—and remembers going backstage with his dad and meeting Geddy Lee after the show. Before he was even in his teens, Smith was going to see Pink Floyd, ZZ Top and many other major artists.

Rock music and Fender are part of Smith’s DNA. He joined the Fender Custom Shop in 1995 and in 2006 completed a five-year apprenticeship under acclaimed Senior Master Builder John English. Among many diverse projects with English, Smith worked on a pair of double-neck Stratocaster guitars for Stone Temple Pilots guitarist Dean DeLeo. He has since crafted fine instruments for players and acts including John 5, Michael Landau, Flea, Josh Klinghoffer, Steve Harris, Reggie Hamilton, Linkin Park, Kenny Wayne Shepherd, Neon Trees and many others.

TODD KRAUSE



Todd Krause

Todd Krause has built exquisitely crafted custom instruments for many of the world’s greatest artists, including Jeff Beck, Eric Clapton, Bob Dylan, David Gilmour, Robbie Robertson, Kenny Wayne Shepherd, Robin Trower, Roger Waters and many others.

His guitar-building apprenticeship began in early 1981 at Jackson/Charvel guitars. Krause arrived at Fender in 1991 and steadily rose through several roles, including one-off instrument builder, R&D model maker, and woodworking machinist. He became a Custom Shop Master Builder in 1997 and has created countless distinctive instruments, all of which embody his personal design philosophy: “Form and function are the biggest part of it,” he said. “It’s about the way an instrument sounds and feels. It has to look cool, and it has to compel you to play.”

GREG FESSLER



Greg Fessler came to the Fender Custom Shop in 1990, working his way up through the ranks as an apprentice. He assisted with the Robben Ford signature line of guitars, eventually becoming the sole builder of those instruments and, later, Ford’s personal builder. Fessler has built one-off Stratocaster and Telecaster models for a host of players, including Joe Bonnamasa, Jeff Healey, Hank Marvin, John Mayer, Rhonda Smith, Neil Schon and Pete Wentz, to name a few.

Fessler’s remarkable abilities as a Master Builder have earned him accolades from many Fender artists and from discerning customers worldwide. His meticulous attention to detail is exemplified in every instrument he creates, each of which is a perfect example of the intense commitment it takes to earn the title of Master Builder.

RON THORN



Ron Thorn brings his decades of expertise in guitar luthiery, namely inlay work, to The Fender Custom Shop. Thorn’s relationship with the Custom Shop team began with his inlay business, Thorn Inlay—which has been the sole inlay provider for the Fender Custom Shop since the mid-90s. He’s also built more than 800 custom instruments under the name Thorn Guitars. Thorn is among the first to assume the title Principal Master Builder—one of the highest honors in the Fender Custom Shop and the guitar building community.

Ron Thorn

YURIY SHISHKOV



From handcrafting many of his own woodworking tools to showcasing his world-class luthier skills and custom inlay work, Yuriy Shishkov is truly one of the last of the renaissance guitar builders. It was in the small confines of a root cellar in his hometown of Gomel in the former Soviet Union that Shishkov got his start building guitars for friends and colleagues.

When he arrived in the United States in 1990, Shishkov settled in the Chicago area and collaborated with a range of top artists, including late shredder Dimebag Darrel, Jimmy Page and Robert Plant, Nuno Bettencourt and Paul Stanley of Kiss. Shishkov joined the Fender Custom Shop’s Master Builder team in 2000, and continues to craft truly magnificent instruments featuring exquisite detail and inlay work as the Fender Custom Shop’s Principal Master Builder.

Yuriy Shishkov



DENNIS GALUSZKA

Like Fender itself, Dennis Galuszka is a Southern California native. Combining his dual passions for music and woodworking, he began building high-end acoustic guitars during his 13 years as a cabinetmaker. As a working drummer, it was a 1999 audition with one of the Fender Master Builders that led to a job interview and a new kind of steady gig—as an apprentice at the Fender Custom Shop.

After only eight months there, Galuszka was promoted to Master Builder. He has since built finely crafted instruments for influential players including Paul McCartney, Andy Summers, Johnny Marr, Patrick Stump, Mike Dirnt, Sting and many others. He has lent his expertise to a number of truly distinctive instruments, including double-neck guitars and unusual takes on classic Fender designs along with several artist models. “It’s all about the feel and sound of an instrument,” Galuszka said. “Those things are number one with me, above everything else.”

Dennis Galuszka

CARLOS LOPEZ



Carlos Lopez received his first electric guitar – an American Standard Stratocaster – as a teenager, and hasn't looked back since. The East Los Angeles native graduated from the Musician's Institute Guitar Craft program in 2006 and was hired by Fender mere months later as an assembly builder. Promoted to the Custom Shop in 2007, he spent the next eight years in the Team Built division, honing his Fender chops and assisting Master Builders on various projects.

11 Lopez became an Apprentice Master Builder under Todd Krause in 2017, assisting with guitars for Eric Clapton, Jeff Beck, Robbie Robertson, Kenny Wayne Shepherd, Robin Trower and others. He has also helped craft an array of distinctive Fender creations, including a stunning '69 Tele Relic in Green Tinted Ice Blue Metallic and, alongside Custom Shop Master Builder Scott Buehl, a transparent acrylic Stratocaster played by Grammy-winning artist Gabriella "H.E.R." Wilson at the 2019 Grammy awards ceremony.

VINCENT VAN TRIGT



Originally from the Netherlands, Vincent moved to California in 2005 and began working for Fender immediately. After wearing a variety of hats in different departments, he started in the Custom Shop in 2012.

A 2-year assistant role with Stephen Stern at the Gretsch Custom Shop was followed by a 5-year apprenticeship with John Cruz. During which he worked on many prestigious guitars, including the replica of Gary Moore's '61 Stratocaster, a 30-piece run of the Jimmie and Stevie Ray Vaughan 30th anniversary Stratocasters, and most recently the Phil Lynott Precision Bass.



KYLE MCMILLIN

Kyle McMillin brings 15 years of musical instrument experience to the Fender Custom Shop. McMillin recently finished a five-year apprenticeship under Principal Master Builder Yuriy Shishkov—working on nearly 1,000 guitars while learning from the esteemed builder. As a newly-minted Master Builder, McMillin is now part of a team of the finest guitar builders—the Fender Custom Shop.



01



BUILD LEVEL: CUSTOM BUILT

Your dreams are what make the Fender Custom Shop the reality that it is today. From its inception in 1987, the Custom Shop has grown from two builders to today's more than 50 artisans—a veteran band of builders, each a specialist dedicated to their own area of expertise—working together to build your ideal Fender to your exact specifications. From neck shaping and fretwork to finishing and aging—every step of creation—each Custom Shop craftsperson brings years of hard-earned skill and dedication to bear on your custom-built guitar with one goal in mind—to create an instrument and playing experience that can only come from the Fender Custom Shop.

A Fender Custom-Built guitar lets you define your ideal instrument. Begin with one of our base models and choose from our vast selection of options to customize it as little or as much as you want to meet your personal needs, aesthetic taste and playing style.

Whatever shape your dream may be, our luthiers stand ready to craft an instrument that will unlock your utmost creativity and self-expression. Their passion is bringing your dreams to reality, to create the ultimate instrument—one personally customized exclusively for you.

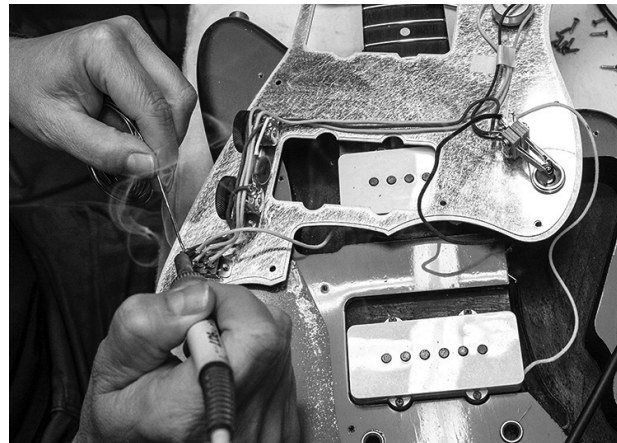

02



SELECT A BASE MODEL

Each base model includes specifications listed as period accurate but can be customized based on the player's playing style and taste.

STRATOCASTER BASE MODELS

1955 STRATOCASTER

SHOWN IN 2-COLOR SUNBURST



- BODY WOOD** ASH
- BODY FINISH** NITROCELLULOSE LACQUER
- NECK WOOD** MAPLE
- NECK SHAPE** '55 "U"
- FINGERBOARD** 1-PIECE MAPLE
- RADIUS** 7.25"
- FRET SIZE** VINTAGE
- FACE DOTS** BLACK MICARTA – WIDE SPACING
- NUT** MICARTA
- TUNERS** FENDER GOTOH VINTAGE
- HARDWARE** NICKEL / CHROME
- BRIDGE** VINTAGE SYNCHRONIZED TREMOLO
- PICKGUARD** 1-PLY WHITE
- WIRING** VINTAGE STRAT W/ 3-WAY SWITCH
- PICKUPS** FCS 1950S STRAT

1956 STRATOCASTER

SHOWN IN WHITE-BLONDE



- BODY WOOD** ALDER
- BODY FINISH** NITROCELLULOSE LACQUER
- NECK WOOD** MAPLE
- NECK SHAPE** 10/56 "V"
- FINGERBOARD** 1-PIECE MAPLE
- RADIUS** 7.25"
- FRET SIZE** VINTAGE
- FACE DOTS** BLACK MICARTA – WIDE SPACING
- NUT** MICARTA
- TUNERS** FENDER GOTOH VINTAGE
- HARDWARE** NICKEL / CHROME
- BRIDGE** VINTAGE SYNCHRONIZED TREMOLO
- PICKGUARD** 1-PLY WHITE
- WIRING** VINTAGE STRAT W/ 3-WAY SWITCH
- PICKUPS** FCS 1950S STRAT

1960 STRATOCASTER

SHOWN IN DAKOTA RED



- BODY WOOD** ALDER
- BODY FINISH** NITROCELLULOSE LACQUER
- NECK WOOD** MAPLE
- NECK SHAPE** '60S OVAL "C"
- FINGERBOARD** SLAB ROSEWOOD
- RADIUS** 7.25"
- FRET SIZE** VINTAGE
- FACE DOTS** CLAY – WIDE SPACING
- NUT** MICARTA
- TUNERS** FENDER GOTOH VINTAGE
- HARDWARE** NICKEL / CHROME
- BRIDGE** VINTAGE SYNCHRONIZED TREMOLO
- PICKGUARD** 3-PLY WHITE
- WIRING** VINTAGE STRAT W/ 3-WAY SWITCH
- PICKUPS** FCS 1960S STRAT

1963 STRATOCASTER

SHOWN IN 3-COLOR SUNBURST



- BODY WOOD** ALDER
- BODY FINISH** NITROCELLULOSE LACQUER
- NECK WOOD** MAPLE
- NECK SHAPE** 60S OVAL "C"
- FINGERBOARD** ROUND-LAM ROSEWOOD
- RADIUS** 7.25"
- FRET SIZE** VINTAGE
- FACE DOTS** CLAY – NARROW SPACING
- NUT** MICARTA
- TUNERS** FENDER GOTOH VINTAGE
- HARDWARE** NICKEL / CHROME
- BRIDGE** VINTAGE SYNCHRONIZED TREMOLO
- PICKGUARD** 3-PLY WHITE
- WIRING** VINTAGE STRAT W/ 3-WAY SWITCH
- PICKUPS** FCS 1960S STRAT

1965 STRATOCASTER

SHOWN IN AZTEC GOLD



BODY WOOD ALDER
BODY FINISH NITROCELLULOSE LACQUER
NECK WOOD MAPLE
NECK SHAPE '65 "C"
FINGERBOARD ROUND-LAM ROSEWOOD
RADIUS 7.25"
FRET SIZE VINTAGE
FACE DOTS PEARL – NARROW SPACING
NUT MICARTA
TUNERS FENDER GOTOH VINTAGE
HARDWARE NICKEL / CHROME
BRIDGE VINTAGE SYNCHRONIZED TREMOLO
PICKGUARD 3-PLY WHITE
WIRING VINTAGE STRAT W/ 3-WAY SWITCH
PICKUPS FCS 1965 STRAT

1969 STRATOCASTER

SHOWN IN SONIC BLUE



BODY WOOD ALDER
BODY FINISH NITROCELLULOSE LACQUER
NECK WOOD MAPLE – URETHANE FINISH
NECK SHAPE '69 "C"
FINGERBOARD ROUND-LAM ROSEWOOD OR MAPLE
RADIUS 7.25"
FRET SIZE VINTAGE
FACE DOTS PEARL WHITE OR BLACK
NUT MICARTA
TUNERS SCHALLER "F"
HARDWARE NICKEL / CHROME
BRIDGE VINTAGE SYNCHRONIZED TREMOLO
PICKGUARD 3-PLY WHITE
WIRING VINTAGE STRAT W/ 3-WAY SWITCH
PICKUPS FCS 1969 STRAT

TELECASTER BASE MODELS

1951 NOCASTER

SHOWN IN HONEY BLONDE



BODY WOOD ASH
BODY FINISH NITROCELLULOSE LACQUER
NECK WOOD MAPLE
NECK SHAPE NOCASTER "U"
FINGERBOARD 1-PIECE MAPLE
RADIUS 7.25"
FRET SIZE F VINTAGE
FACE DOTS BLACK MICARTA – NARROW SPACING
NUT MICARTA
TUNERS FENDER GOTOH VINTAGE
HARDWARE NICKEL / CHROME
BRIDGE VINTAGE WITH BRASS SADDLES
PICKGUARD 1-PLY BLACK
WIRING VINTAGE TELE W/ 3-WAY SWITCH
PICKUPS FCS 1951 NOCASTER

1952 TELECASTER

SHOWN IN 2-COLOR SUNBURST



BODY WOOD ASH
BODY FINISH NITROCELLULOSE LACQUER
NECK WOOD MAPLE
NECK SHAPE '52 "U"
FINGERBOARD 1-PIECE MAPLE
RADIUS 7.25"
FRET SIZE VINTAGE
FACE DOTS BLACK MICARTA – WIDE SPACING
NUT MICARTA
TUNERS FENDER GOTOH VINTAGE
HARDWARE NICKEL / CHROME
BRIDGE VINTAGE WITH BRASS SADDLES
PICKGUARD 1-PLY BLACK
WIRING VINTAGE TELE W/ 3-WAY SWITCH
PICKUPS FCS 1951 NOCASTER

ELITE STRATOCASTER

SHOWN IN SURF PEARL



BODY WOOD ALDER
BODY FINISH NITROCELLULOSE LACQUER
NECK WOOD AAA FLAME MAPLE
NECK SHAPE MODERN "C TO D"
FINGERBOARD 1-PIECE ROSEWOOD OR 1-PIECE MAPLE
RADIUS 9.5" - 14"
FRET SIZE MEDIUM JUMBO
FACE DOTS MOP/BLACK
NUT BONE
TUNERS LACKING
HARDWARE CHROME
BRIDGE CUSTOM CLASSIC
PICKGUARD 3-PLY PARCHMENT
WIRING MODERN
PICKUPS N4 NOISELESS

1960 TELECASTER

SHOWN IN WHITE BLONDE



BODY WOOD ALDER
BODY FINISH NITROCELLULOSE LACQUER
NECK WOOD MAPLE
NECK SHAPE '60S OVAL "C"
FINGERBOARD SLAB ROSEWOOD
RADIUS 7.25"
FRET SIZE VINTAGE
FACE DOTS CLAY – NARROW SPACING
NUT MICARTA
TUNERS FENDER GOTOH VINTAGE
HARDWARE NICKEL / CHROME
BRIDGE VINTAGE WITH THREADED SADDLES
PICKGUARD 3-PLY WHITE
WIRING VINTAGE TELE W/ 3-WAY SWITCH
PICKUPS FCS '60 - '63 TELECASTER

1960 TELECASTER CUSTOM

SHOWN IN BLACK



BODY WOOD DOUBLE-BOUND ALDER
BODY FINISH NITROCELLULOSE LACQUER
NECK WOOD MAPLE
NECK SHAPE | '60S OVAL "C"
FINGERBOARD | SLAB ROSEWOOD
RADIUS 7.25"
FRET SIZE VINTAGE
FACE DOTS CLAY
NUT MICARTA
TUNERS FENDER GOTOH VINTAGE
HARDWARE NICKEL / CHROME
BRIDGE VINTAGE WITH THREADED SADDLES
PICKGUARD 3-PLY WHITE
WIRING VINTAGE TELE W/ 3-WAY SWITCH
PICKUPS FCS '60 - '63 TELECASTER

1963 TELECASTER

SHOWN IN LAKE PLACID BLUE



BODY WOOD ALDER
BODY FINISH NITROCELLULOSE LACQUER
NECK WOOD MAPLE
NECK SHAPE '60S OVAL "C"
FINGERBOARD ROUND-LAM ROSEWOOD
RADIUS 7.25"
FRET SIZE VINTAGE
FACE DOTS CLAY
NUT MICARTA
TUNERS FENDER GOTOH VINTAGE
HARDWARE NICKEL / CHROME
BRIDGE VINTAGE WITH THREADED SADDLES
PICKGUARD 3-PLY WHITE
WIRING VINTAGE TELE W/ 3-WAY SWITCH
PICKUPS FCS '60 - 63 TELECASTER

1967 TELECASTER

SHOWN IN CANDY APPLE RED



BODY WOOD ALDER
BODY FINISH NITROCELLULOSE LACQUER
NECK WOOD MAPLE
NECK SHAPE '60S OVAL "C"
FINGERBOARD ROSEWOOD OR MAPLE
RADIUS 7.25"
FRET SIZE VINTAGE
FACE DOTS PEARL WHITE OR BLACK MICARTA
NUT MICARTA
TUNERS SCHALLER "F"
HARDWARE NICKEL / CHROME
BRIDGE VINTAGE WITH THREADED SADDLES
PICKGUARD 3-PLY WHITE
WIRING VINTAGE TELE W/ 3-WAY SWITCH
PICKUPS FCS 1967 TELECASTER

1950's THINLINE TELECASTER

SHOWN IN 2-COLOR SUNBURST



BODY WOOD ASH
BODY FINISH NITROCELLULOSE LACQUER
NECK WOOD MAPLE
NECK SHAPE NOCASTER "U"
FINGERBOARD 1-PIECE MAPLE
RADIUS 7.25"
FRET SIZE VINTAGE
FACE DOTS CLAY - NARROW SPACING
NUT MICARTA
TUNERS FENDER GOTOH VINTAGE
HARDWARE NICKEL / CHROME
BRIDGE VINTAGE WITH BRASS SADDLES
PICKGUARD 1-PLY WHITE
WIRING VINTAGE TELE W/ 3-WAY SWITCH
PICKUPS FCS 1951 NOCASTER

PRECISION BASS BASE MODELS

ELITE TELECASTER

SHOWN IN CAMPAIGN METALLIC



BODY WOOD ALDER
BODY FINISH NITROCELLULOSE LACQUER
NECK WOOD AAA FLAME MAPLE
NECK SHAPE MODERN "C TO D"
FINGERBOARD ROSEWOOD OR MAPLE
RADIUS 9.5" - 14"
FRET SIZE MED JUMBO
FACE DOTS MOP/BLACK
NUT BONE
TUNERS LOCKING
HARDWARE CHROME
BRIDGE ELITE TELE
PICKGUARD 3-PLY PARCHMENT
WIRING ELITE TELE
PICKUPS N4 NOISELESS

1959 ESQUIRE

SHOWN IN 3-COLOR SUNBURST



BODY WOOD ASH
BODY FINISH NITROCELLULOSE LACQUER
NECK WOOD MAPLE
NECK SHAPE '59 "C"
FINGERBOARD SLAB ROSEWOOD OR MAPLE
RADIUS 7.25"
FRET SIZE VINTAGE
FACE DOTS MICARTA BLACK - WIDE SPACING
NUT MICARTA
TUNERS FENDER GOTOH VINTAGE
HARDWARE NICKEL / CHROME
BRIDGE VINTAGE '59 W/THREADED
PICKGUARD 1-PLY PARCHMENT
WIRING VINTAGE ESQUIRE 3-WAY SWITCH
PICKUPS FCS VINTAGE TELECASTER

1955 PRECISION BASS

SHOWN IN VINTAGE BLONDE



BODY WOOD ASH
BODY FINISH NITROCELLULOSE LACQUER
NECK WOOD QUARTERSAWN MAPLE
NECK SHAPE '55 PBASS SOFT "V"
FINGERBOARD 1-PIECE MAPLE
RADIUS 7.25"
FRET SIZE VINTAGE
FACE DOTS CLAY
NUT MICARTA
TUNERS FENDER GOTOH REVERSE
HARDWARE NICKEL / CHROME
BRIDGE VINTAGE
PICKGUARD 1-PLY WHITE
WIRING VINTAGE PRECISION BASS
PICKUPS FCS 1950S PRECISION BASS

1959 PRECISION BASS

SHOWN IN BLACK



BODY WOOD ALDER
BODY FINISH NITROCELLULOSE LACQUER
NECK WOOD QUARTERSAWN MAPLE
NECK SHAPE '60S PBASS OVAL "C"
FINGERBOARD SLAB ROSEWOOD
RADIUS 7.25"
FRET SIZE VINTAGE
FACE DOTS CLAY
NUT MICARTA
TUNERS FENDER GOTOH REVERSE
HARDWARE NICKEL / CHROME
BRIDGE VINTAGE
PICKGUARD GOLD ANODIZED
WIRING VINTAGE PRECISION BASS
PICKUPS FCS '59 - '62 BASS

1960 PRECISION BASS

SHOWN IN 3-COLOR SUNBURST



BODY WOOD	ASH
BODY FINISH	NITROCELLULOSE LACQUER
NECK WOOD	MAPLE
NECK SHAPE	'60S PBASS OVAL "C"
FINGERBOARD	SLAB ROSEWOOD
RADIUS	7.25"
FRET SIZE	VINTAGE
FACE DOTS	CLAY
NUT	MICARTA
TUNERS	FENDER GOTOH REVERSE
HARDWARE	NICKEL / CHROME
BRIDGE	VINTAGE
PICKGUARD	4-PLY TORTOISE SHELL
WIRING	VINTAGE PRECISION BASS
PICKUPS	FCS '59 - '62 BASS

OFFSET BASE MODELS

1962 JAZZMASTER

SHOWN IN SURF GREEN



BODY WOOD	ALDER
BODY FINISH	NITROCELLULOSE LACQUER
NECK WOOD	MAPLE
NECK SHAPE	JAZZMASTER "C"
FINGERBOARD	SLAB ROSEWOOD
RADIUS	7.25"
FRET SIZE	VINTAGE
FACE DOTS	CLAY
NUT	MICARTA
TUNERS	FENDER GOTOH VINTAGE
HARDWARE	NICKEL / CHROME
BRIDGE	VINTAGE JAGUAR/JAZZMASTER
PICKGUARD	3-PLY WHITE
WIRING	VINTAGE JAZZMASTER
PICKUPS	FCS JAZZMASTER

1962 JAGUAR

SHOWN IN FIESTA RED



BODY WOOD	ALDER
BODY FINISH	NITROCELLULOSE LACQUER
NECK WOOD	MAPLE
NECK SHAPE	JAGUAR "C"
FINGERBOARD	SLAB ROSEWOOD
RADIUS	7.25"
FRET SIZE	VINTAGE
FACE DOTS	CLAY
NUT	MICARTA
TUNERS	FENDER GOTOH VINTAGE
HARDWARE	NICKEL / CHROME
BRIDGE	VINTAGE JAGUAR/JAZZMASTER
PICKGUARD	3-PLY WHITE
WIRING	VINTAGE JAGUAR
PICKUPS	FCS JAGUAR

JAZZ BASS BASE MODEL

1964 JAZZ BASS

SHOWN IN SONIC BLUE



BODY WOOD	ALDER
BODY FINISH	NITROCELLULOSE LACQUER
NECK WOOD	MAPLE
NECK SHAPE	'60 "U"
FINGERBOARD	ROUND-LAM ROSEWOOD
RADIUS	7.25"
FRET SIZE	VINTAGE
FACE DOTS	CLAY
NUT	MICARTA
TUNERS	FENDER GOTOH REVERSE
HARDWARE	NICKEL / CHROME
BRIDGE	VINTAGE
PICKGUARD	4-PLY TORTOISE SHELL
WIRING	VINTAGE JAZZ BASS
PICKUPS	FCS VINTAGE JAZZ BASS

BASS VI

SHOWN IN 3-COLOR SUNBURST



BODY WOOD	ALDER
BODY FINISH	NITROCELLULOSE LACQUER
NECK WOOD	QUARTERSAWN MAPLE
NECK SHAPE	"C"
FINGERBOARD	SLAB ROSEWOOD
RADIUS	7.25"
FRET SIZE	VINTAGE
FACE DOTS	CLAY
NUT	MICARTA
TUNERS	FENDER GOTOH VINTAGE
HARDWARE	NICKEL / CHROME
BRIDGE	VINTAGE JAGUAR
PICKGUARD	4-PLY TORTOISE SHELL
WIRING	VINTAGE BASS VI
PICKUPS	FCS JAGUAR

03



SELECT AN
AGING STYLE

NEW OLD STOCK(NOS)

SHOWN IN 1956 STRATOCASTER IN WHITE BLONDE

Models from the past that have survived to the present day looking brand new. An all-lacquer finish that looks as if it hasn't aged at all-as if you went back in time and bought it.



CLOSET CLASSIC

SHOWN IN LIMITED EDITION 1958 JAZZMASTER IN 2-COLOR SUNBURST

No real playing wear, but more subtle indications of the ages, such as a finish that has lost its sheen, mild discoloration of plastic parts, metal hardware showing slight oxidation, "mild" finish checking and minor surface scratches on the body and headstock.



DLX CLOSET CLASSIC

SHOWN IN POST-MODERN TELECASTER IN FADED FIREMIST SILVER

Well taken care of and religiously polished throughout the years. The owner of this guitar took pride in keeping it clean and shiny. Over time the finish started showing age and like a fine wine it evolved into something complex and refined. Moderate finish checking, oxidation of hardware, and mild discoloration of parts give this finish its distinct look and feel.



JOURNEYMAN RELIC®

SHOWN IN 1959 JAZZMASTER IN AGED FIESTA RED

Well taken care of and religiously polished throughout the years. The owner of this guitar took pride in keeping it clean and shiny. Over time the finish started showing age and like a fine wine it evolved into something complex and refined. Moderate finish checking, oxidation of hardware, and mild discoloration of parts give this finish its distinct look and feel.



RELIC®

SHOWN IN 1960 STRATOCASTER IN AGED DAPHNE BLUE

The Authentic worn-in wear of a guitar that has experienced many years of regular use in clubs and bars. Marks that tell a story, finish checking all over the body; scars dings and dents from bridge to headstock.



HEAVY RELIC®

SHOWN IN 1953 TELECASTER IN BUTTERSCOTCH BLONDE

The heaviest of the relic treatments, designed to evoke decades of the most punishing play and touring. From serious dinged and wear to intensely discolored hardware and finish, the true battle-hardened workhorse.



LTD 58 STRAT® JOURNEYMAN RELIC®
W/ CLOSET CLASSIC HARDWARE
AGED SHERWOOD GREEN METALLIC - 9235001384

04



SELECT
YOUR OPTIONS

TONewood OPTIONS

BODY WOOD OPTIONS



ALDER

A fantastic tone wood long used by Fender for its electric guitar bodies, alder is noted for bright, balanced and resonant tone with pronounced upper midrange, excellent sustain and sharp attack. It also features large, swirling grain patterns.



ASH

Strong and dense, ash is a longtime Fender classic for electric instrument bodies. Notably resonant and sweet sounding, it's characterized by well-defined midrange and strong low end.



MAHOGANY

A dense, dark tone wood that yields warm tone and midrange bite, mahogany is a great option that adds a unique and complex sonic and visual twist to your build.

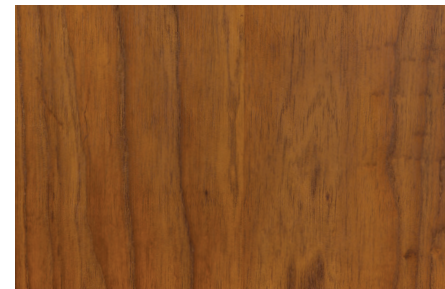

ROASTED ASH

Strong and ultra-stable, a roasted ash body is a thing of beauty. Not only does the roasting process accentuate the figuring of the wood, it also crystallizes the sap, giving it the sound of old wood.



OKUME

A warm-sounding tone wood with figured grain patterns that make it an excellent choice for a guitar body spread.

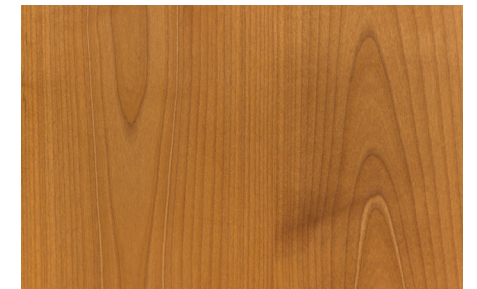

ROASTED ALDER

The roasting process will darken the wood while keeping it very stable and durable. As with a slab of wood that has dried over the years, the properties change slightly and add to the richness and depth of tone.

QUILT/FLAME TOP OPTIONS



QUILT MAPLE TOP

A beautifully figured wood, quilt maple works especially well with transparent and natural finishes that allow the flowing grain to show through.



AA FLAME MAPLE TOP

AA flame maple features tiger-like striping in the wood grain. Many believe that this is caused by the tree swaying in the wind, the minerals in the ground and other ephemeral variables. We aren't positive about that, but we do know it provides a strikingly beautiful look to any instrument neck or body.



AAA FLAME MAPLE TOP

AAA flame maple sorts a more intense concentration of figuring than AA Flame. The bold stripes are always a beautiful touch in natural and transparent finishes.



SPALTED MAPLE

Spalted maple combines excellent strength and bright, crisp tone with incredibly unique and captivating figured lines and streaks to give your instrument an elegant look and sound.



KOA

Beautiful and highly stable tone-wood prized for its resonance, workability and attractive figure.



MAPLE BURL

Highly figured maple top used on our Artisan models with a gorgeous marbled swirl.

NECK WOOD OPTIONS



MAPLE NECK

Light in color, with a bright, chimey tone, maple is favorite amongst many Fender players for its look, feel and tone.



FLAME MAPLE

With its strong, vibrant figure, flame maple is one of our favorite ways to liven up the look of a maple neck.



BIRDSEYE MAPLE

Small round figuring in the wood which produces small "birdseye" markings. Used on many Custom Shop guitars, a birdseye maple neck will add a unique and striking look to your guitar.



ROASTED MAPLE NECK

Roasted maple creates an aged and dark look to the wood as well as making it more resonant and slightly lighter in weight.



ROSEWOOD NECK

Darker in color and warmer in tone than maple, rosewood can be specially sorted for a darker color. In 1959, all Fenders were outfitted with rosewood fingerboards, which was a significant departure from the look and tone of the previous maple boards.



ROASTED FLAME MAPLE

Roasting maple brings out the figure and creates a caramelized dark tiger striping.

NECK TINT OPTIONS



LIGHT TINT

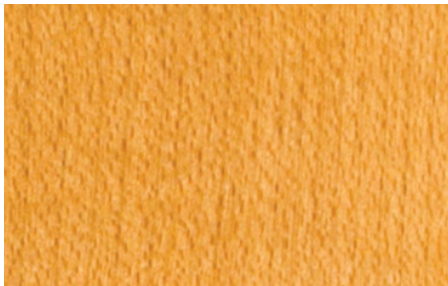

MEDIUM TINT



DARK TINT



SELECT A COLOR OPTION



00 3 COLOR SUNBURST



04 DAPHNE BLUE



08 OCEAN TURQUOISE



15 HOT ROD RED



20 AMBER



24 INCA SILVER



28 CRIMSON BURST



32 BROWN SUNBURST



37 ANTIQUE BURST



01 WHITE BLONDE

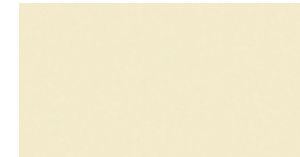

05 OLYMPIC WHITE



09 CANDY APPLE RED

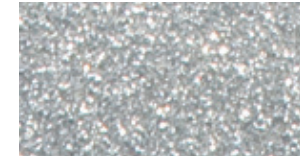

17 SILVER SPARKLE



21 NATURAL



25 CHROME RED



29 BLUE AGAVE

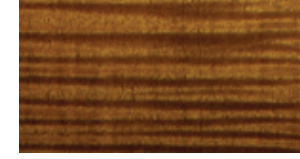

33 VIOLIN BURST



38 CRIMSON TRANS

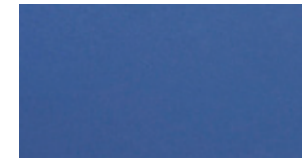

02 LAKE PLACID BLUE



06 BLACK

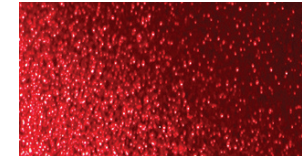

12 RED SPARKLE

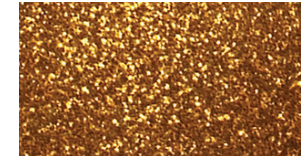

18 GOLD SPARKLE

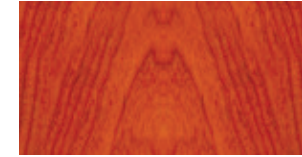

22 SUNSET ORANGE TRANS



26 VIOLET



30 CHERRY SUNBURST



34 AGED NATURAL

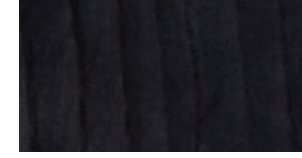

39 EBONY TRANS



03 2 COLOR SUNBURST

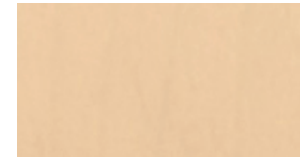

07 VINTAGE BLONDE

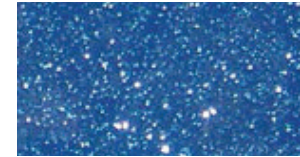

13 BLUE SPARKLE



19 SAGE GREEN METALLIC



23 PEARL WHITE



27 SAPPHIRE BLUE TRANS



31 AGED CHERRY SUNBURST



36 BLUE BURST



40 FIESTA RED



41 VINTAGE WHITE



42 MERCEDES BLUE



43 PEWTER



44 SHORELINE GOLD



83 BLUE ICE METALLIC

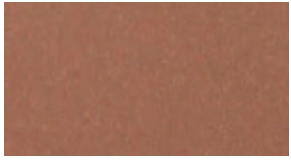

84 COPPER



85 BRIGHT AMBER MET



86 BRIGHT SAPPHIRE MET.



45 TEAL GREEN METALLIC



46 SHERWOOD GREEN MET.



47 SIENNA SUNBURST



48 TEAL GREEN TRANS



87 COBALT BLUE METALLIC



88 DESERT SUNSET



89 DESERT SAND



90 BALTIC BLUE

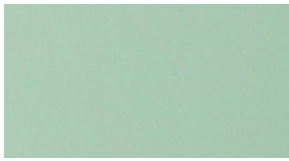

49 SEA FOAM GREEN



52 TOBACCO BURST



53 FIRE MIST GOLD



54 DAKOTA RED



92 WALNUT



93 PURPLE METALLIC

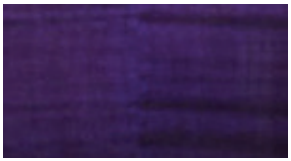

94 PURPLE TRANS



95 | AGED VINTAGE WHITE

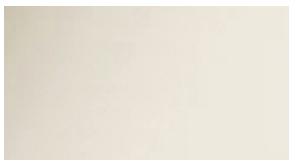

55 FROST WHITE



56 SHELL PINK



57 SURF GREEN



58 TORINO RED



96 ORANGE



97 CHOCOLATE 3 TONE SB

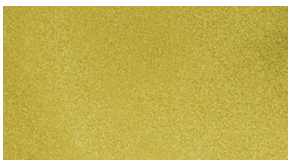

98 HLE GOLD



99 NOCASTER BLONDE

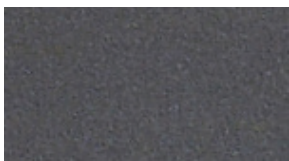

59 BLACK PEARL



60 EMERALD GREEN TRANS

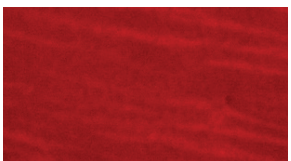

61 BING CHERRY TRANS



62 COBALT BLUE TRANS



BG BRITISH RACING GREEN



BT BUTTERSCOTCH BLONDE

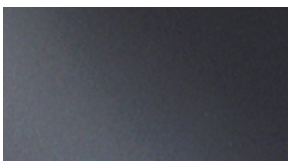

CF CHARCOAL FROST MET



CR CIMARRON RED



63 GRAFFITI YELLOW



66 BURGUNDY MIST MET.



67 HONEY BLONDE



68 LIME GREEN



CS CHARTREUSE SPARKLE

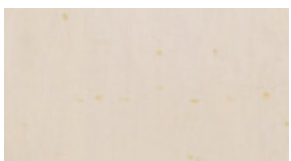

DB DIRTY WHITE BLONDE



HB HONEY BURST

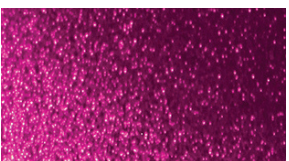

MS MAGENTA SPARKLE



70 CADMIUM ORANGE



71 CANDY GREEN



72 SONIC BLUE



73 MIDNIGHT BLUE



OS ORANGE SPARKLE

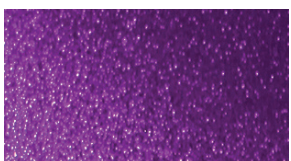

PS PURPLE SPARKLE



SR SEMINOLE RED



SS SEAFOAM GREEN SPARKLE



74 AQUA MARINE METALLIC



75 MIDNIGHT WINE



76 MIDNIGHT PURPLE



77 FROST RED



TT TAOS TURQUOISE



• YOUR COLOR
*Example shown in Fiesta Red.



• YOUR COLOR AGED
Adds a golden tint to simulate aging.

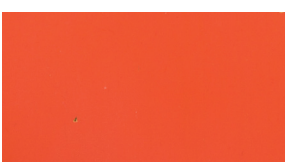

• YOUR COLOR FADED
Creates the look of a color that has faded over time.



78 AZTEC GOLD



79 FROST GOLD

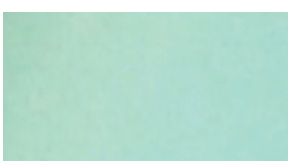

81 SURF PEARL



82 CANDY TANGERINE



SELECT A
NECK SHAPE

GUITAR NECK SHAPES

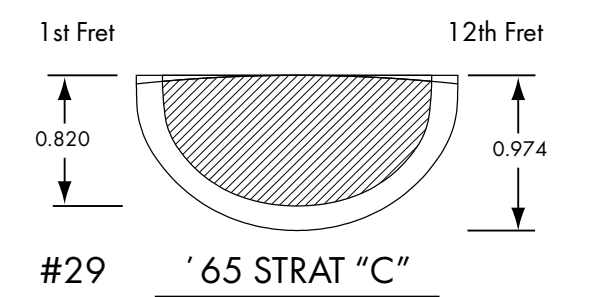
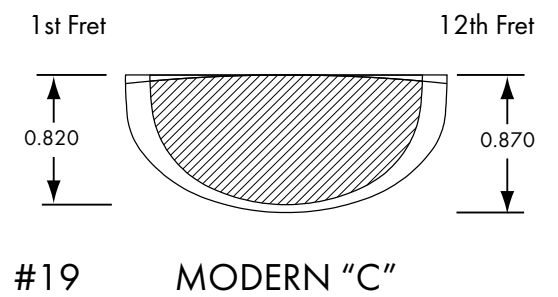
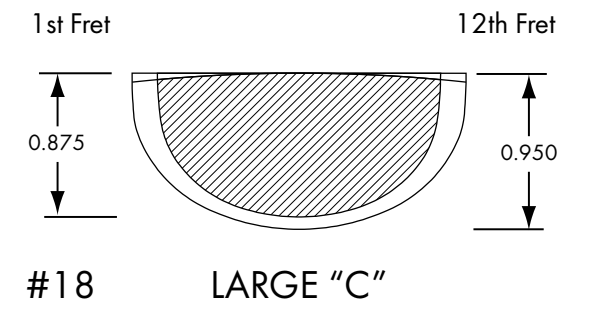
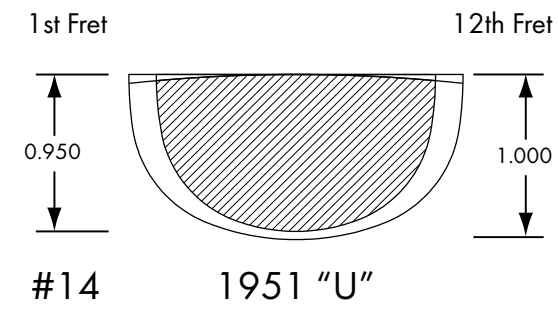
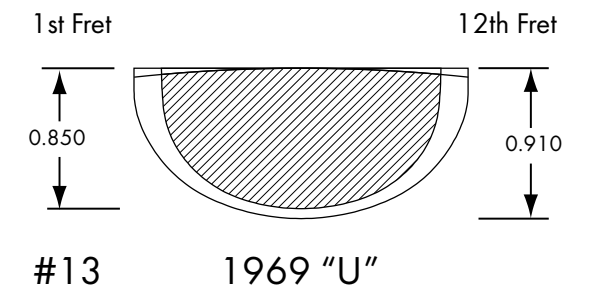
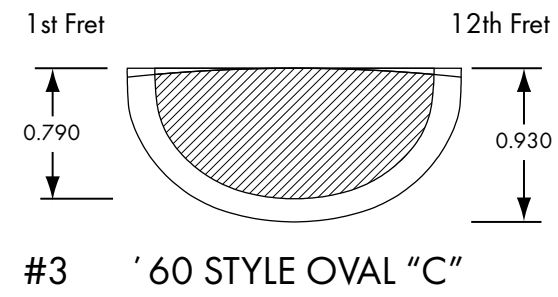
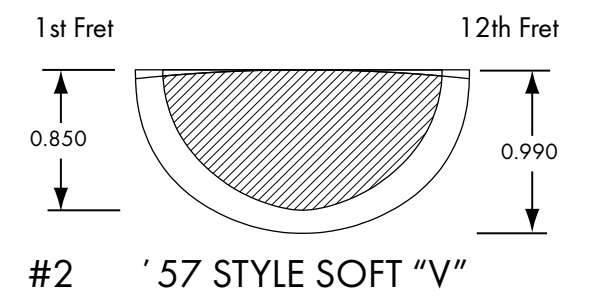
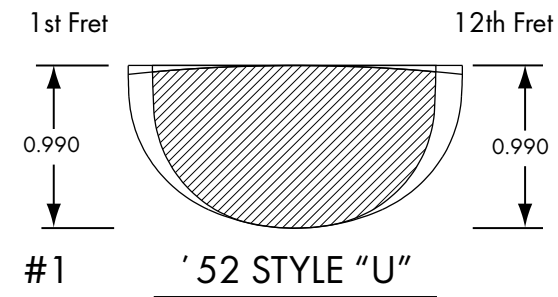

GUITAR NECK SHAPES (CONT.)

BASS NECK SHAPES

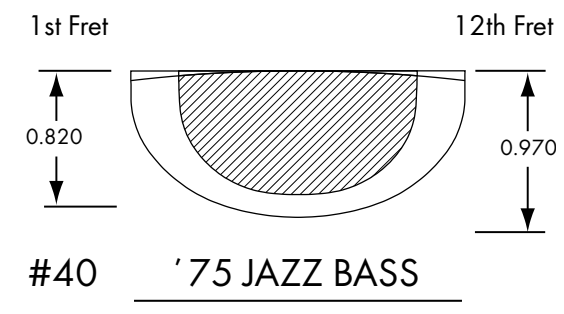
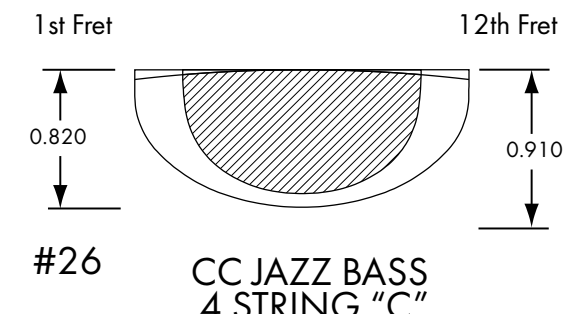
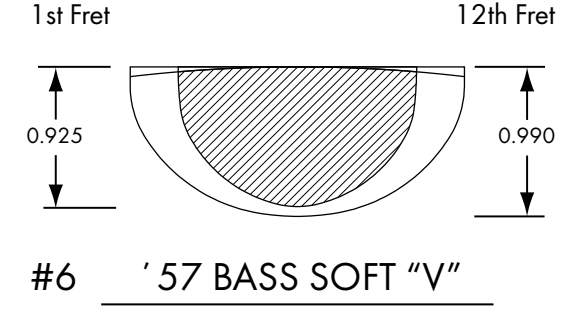
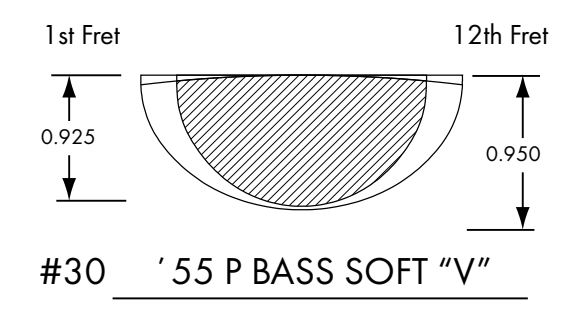
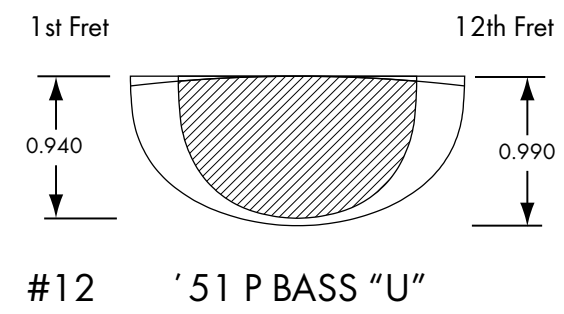
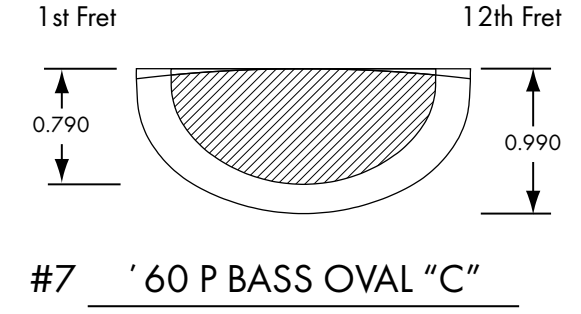
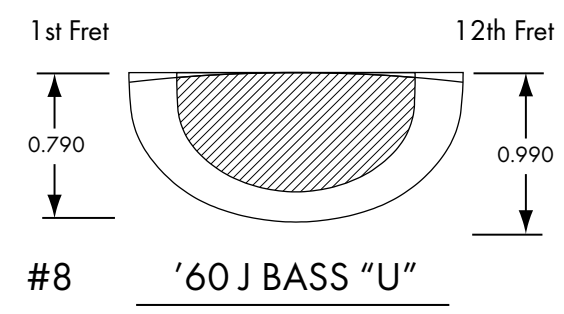
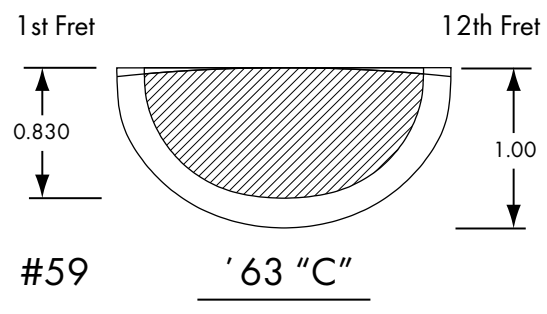
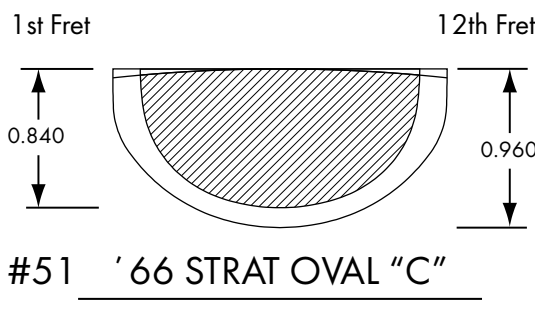
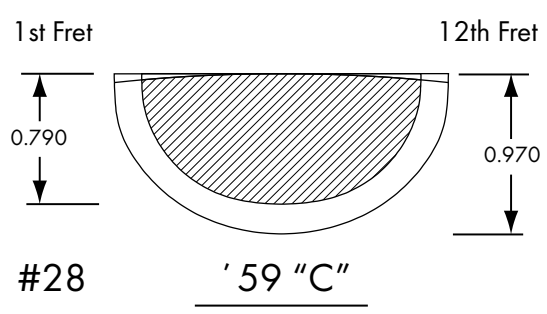
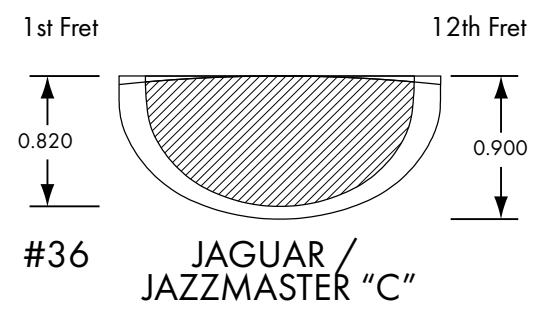
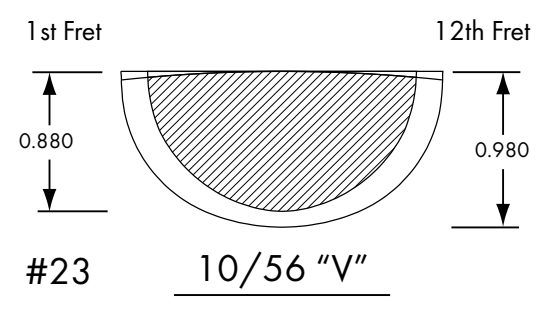
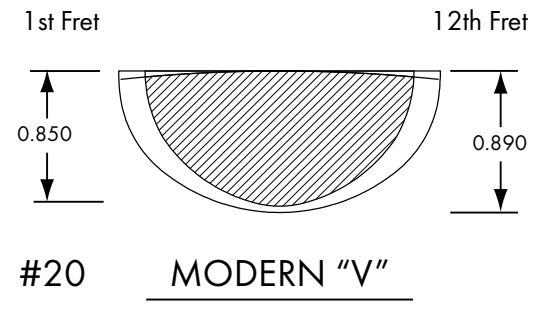



SELECT A FRET WIRE

Custom Shop frets are made from only the highest quality nickel, and can be made in a variety of different heights and thicknesses. Larger frets tend to account for easier string bending. Smaller frets are “true to vintage” in many cases, and facilitate easier chording.

Medium jumbo frets are designed to be the perfect marriage between small vintage frets and modern jumbo frets. Keep the following examples in mind when choosing the frets that you want on your guitar.

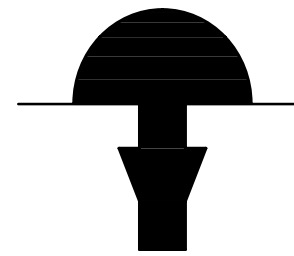

VINTAGE 45085

H: 0.045”
W: 0.085”
Our smallest wire, slightly larger than Fender’s original wire.

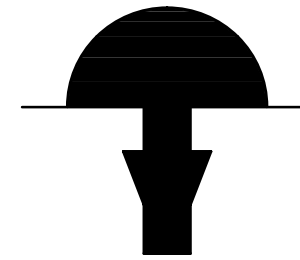

MEDIUM VINTAGE 47095

H: 0.047”
W: 0.095”
Slightly lower than 6105.

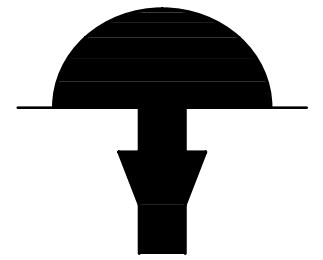

MEDIUM JUMBO 6150

H: 0.047”
W: 0.104”
A popular middle of the road wire, not too wide, not too tall.

*Also available in Stainless Steel on Master Built guitars only.

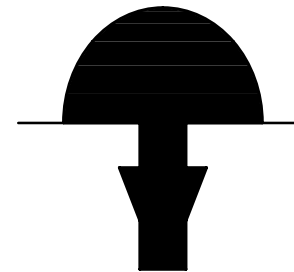

NARROW TALL 6105

H: 0.055”
W: 0.095”
Our most popular wire. A good alternative if vintage wire feels too small for you.

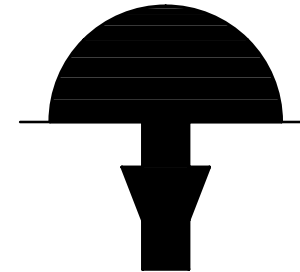

JUMBO 6100

H: 0.057”
W: 0.110”
Our largest wire that gives an almost scalloped feel.

*Also available in Stainless Steel on Master Built guitars only.



SELECT A PICKUP OPTION

Hand-Wound: True to Fender history prior to 1965, hand-wound or “scatter-wound” pickups are distinctly unique in character. Each pickup has its own subtle nuances and personalized character which is what made the original Fender pickups so sought after and prized.

Machine Wound: Each pickup is consistent and even in winds making each one sound and respond relatively the same. Though most of the Custom Shop pickups are hand-wound, some players prefer the consistency of machine-wound pickups, so we are happy to offer both options.

STRATOCASTER PICKUPS



'50S STRAT

Crafted to faithfully replicate the cutting tones reminiscent of 1950s Stratocaster® guitars. Alnico 5 magnets, vintage stagger and formvar wire.



FAT '50S STRAT

1950s Stratocaster sound you know and love. Hot-rodDED wiring design delivers enhanced bass response and an extra shot of 21st-century attitude.



'60S STRAT

Classic 1960s design with alnico 2 magnets, formvar wire and a vintage stagger. Strat sound with glistening highs and warm punchy lows.



TEXAS SPECIAL™ STRAT

Characterized by their midrange chirp, crystalline highs and tight bass, Fender Texas Special™ Strat pickups feature an overwound single-coil construction that produces big Texas-blues tone.



DUAL-MAG STRAT

Vintage style calibrated pickup set with unbeveled alnico 5 magnets on the bass side and beveled alnico 2 magnets on the treble. The two magnet types create balance and consistency in tone and allow for improved clarity string to string.



EL DIABLO STRAT

Overwound and dipped in the special sauce for a big open sound. Slightly hotter than the Ancho Poblano with calibrated alnico 5 pickups with custom low G (middle and neck) and flush with high D (bridge) pole pieces.



ANCHO POBLANO STRAT

Simmered in a secret Custom Shop sauce and then individually calibrated from neck to bridge. Uniquely overwound by hand for a wide range of high-output tones—from blistering-hot output to sizzling vintage warmth—with plenty of tonal flexibility.



VINTAGE NOISELESS™ STRAT

Produce all the brilliant clarity, definition and harmonic attributes of vintage single-coil Strat tone without the hum.



TOMATILLO STRAT

Cousins to the Ancho Poblano, dipped in the same secret sauce. Alnico 2 magnets will simulate what an older alnico 5 might sound like today for a sweeter more flavorful tone.

TELECASTER PICKUPS



'51 TELE/NOCASTER

Created with the original design in mind to accurately mimic the twang and shimmer of the originals. These period-correct single-coil pickups impart tight low end and clear, balanced midrange.



'51 LOADED NOCASTER

Extra winds of #43 gauge enamel wire give these pickups fat, juicy tone. Perfect for driving a preamp into gritty overdrive, these high-output pickups burn with vintage-inspired tone, thanks to the bridge pickup's alnico 3 magnets and neck pickup's alnico 5 magnets.



'56/'57 TELECASTER

An accurate 1:1 recreation of the Tele pickups we constructed during '56/'57. These pickups have all the grunt and snarl of the originals, thanks to the unbeveled, staggered alnico 5 magnets and enamel-coated wire.



'63 TELE

A true replication of the original '63 Tele Pickups with all the bite and warmth to spare. Alnico 2 Magnets, vintage stagger and enamel wire.



'67 TELE

Lower output Tele pickups with Grey bobbins and copper baseplate with a vintage stagger, alnico 5 magnets and enamel wire for crystal clear Tele twang.



TWISTED TELE

High-output Telecaster guitar tone with a dash of sparkling Stratocaster® guitar character.

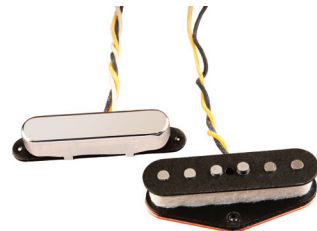

TEXAS SPECIAL TELE

Fender Custom Shop Texas Special Tele pickups are built to produce blistering hot output, along with noticeable presence and midrange.

BASS PICKUPS



'64 JAZZ BASS

These vintage-style pickups produce warm, clear and articulate tone, with great low-end definition, up-front midrange punch and singing high end.



'75 JAZZ BASS

Vintage bobbin construction, Alnico 5 magnets, flush mounted pole pieces and enamel wire provide warm tones, enhanced dynamics and even string response.



NOISELESS JAZZ BASS

Fender Noiseless Jazz Bass pickups produce all the brilliant clarity, definition and harmonic attributes of a vintage Jazz Bass without the hum.



HAND WOUND P-BASS

Alnico 5 magnets and enamel wire, hand-wound just like we did in the '50s and '60s. The most iconic bass pickup in the world.

HUMBUCKER PICKUPS



SHAWBUCKER

Full of multi-dimensional tone with well-defined overtones, this open-coil pickup complements and balances your guitar's natural voice while playing well with other pickup designs.



CuNiFe WIDE RANGE

The look of the famous Fender pickup design of the early 1970s with period correct magnets, as used on original-era Telecaster Thinline, Telecaster Custom and Telecaster Deluxe models.

P-90 PICKUPS



CSP-90

CSP-90 This classic design sings with pure Fender tone, bringing clear articulation to every note you play, from delicately nuanced cleans to snarling, spitting means.





SELECT A
WIRING OPTION

STRATOCASTER WIRING

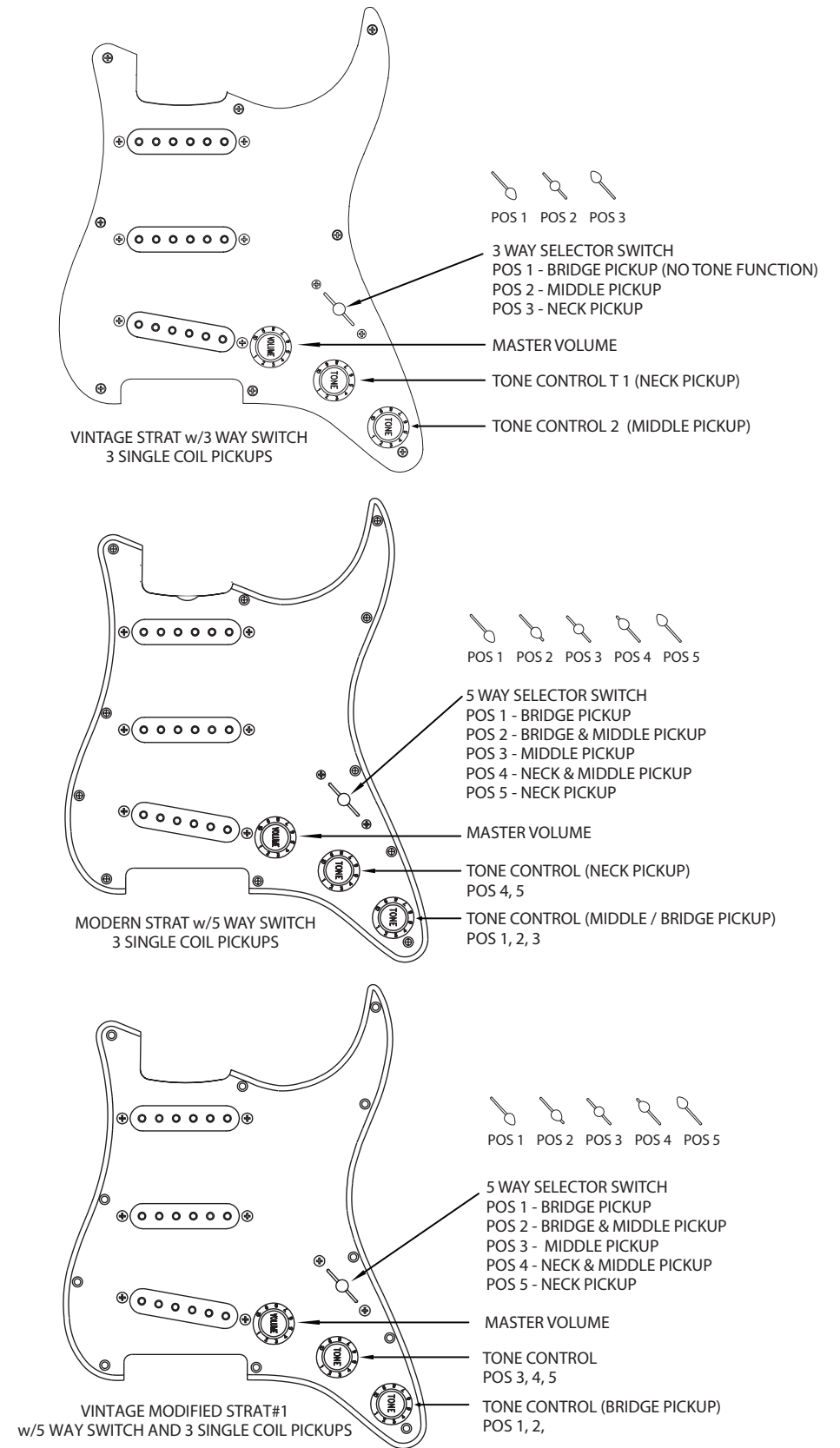

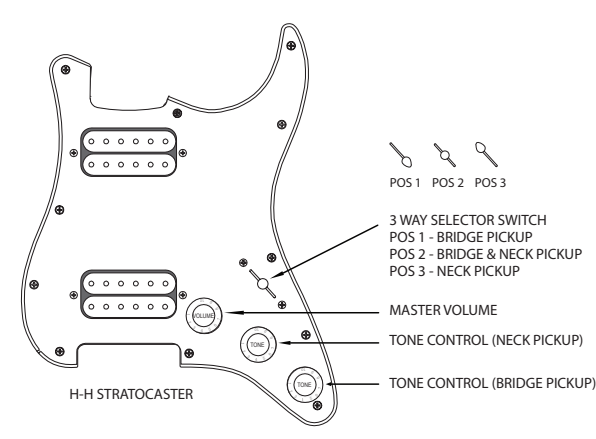
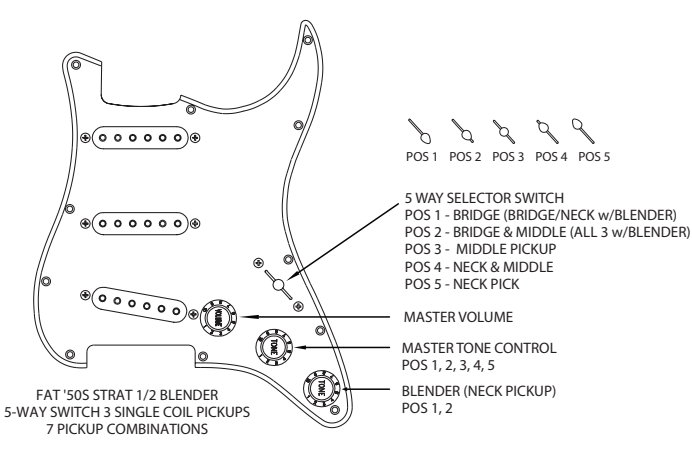
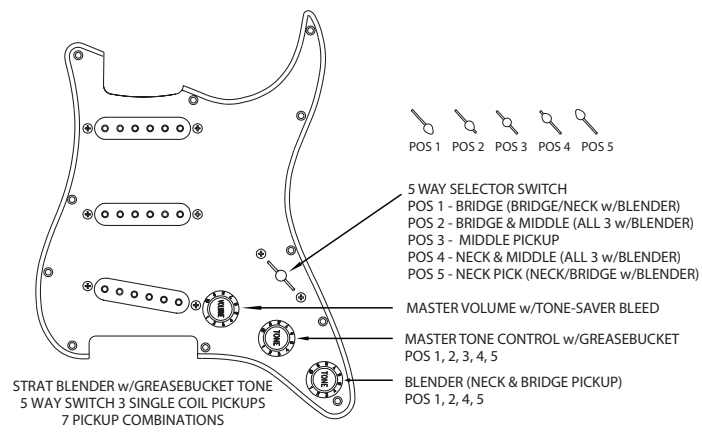
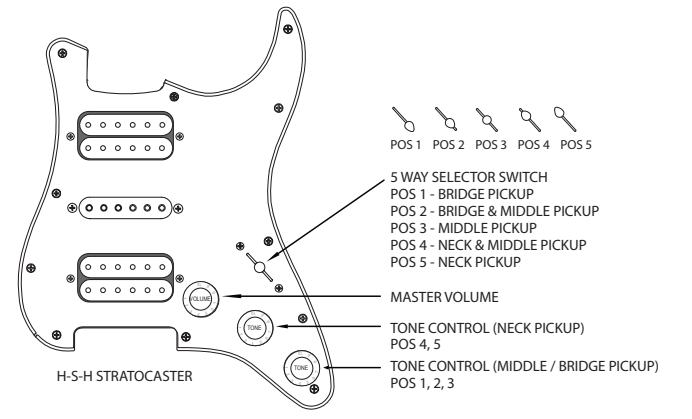
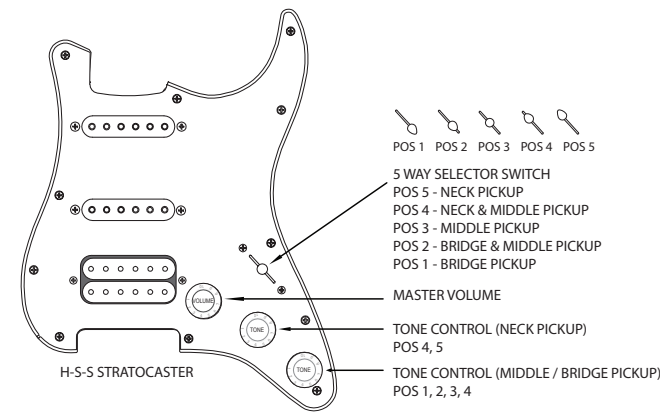
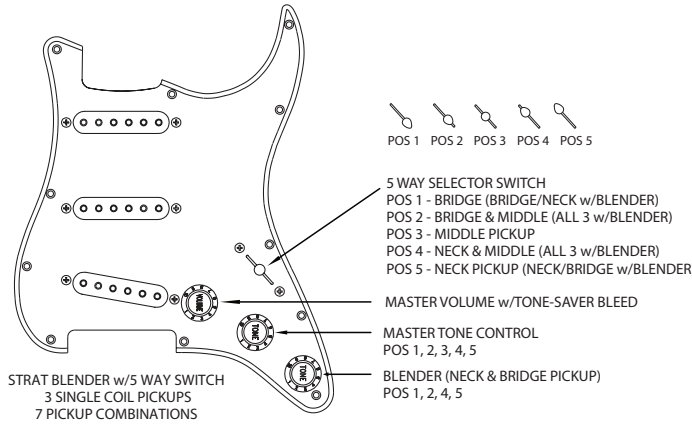
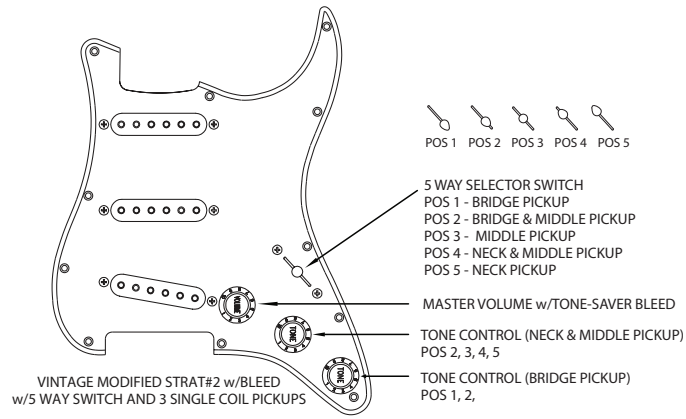

TELECASTER WIRING

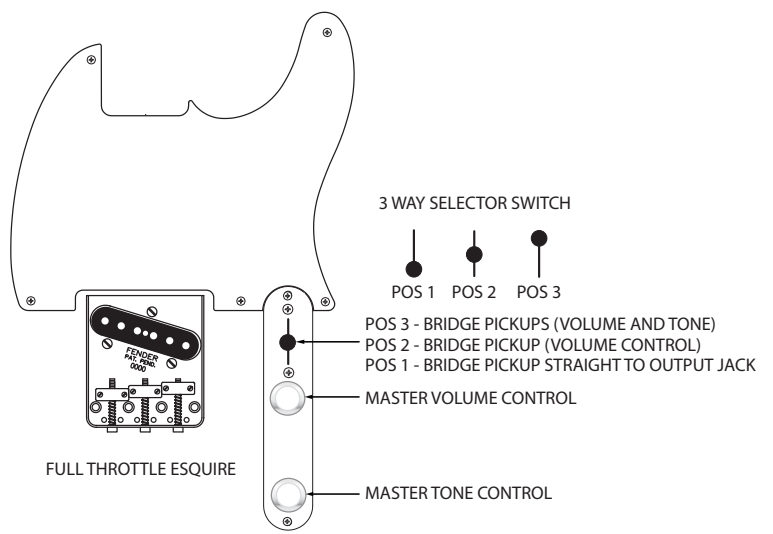
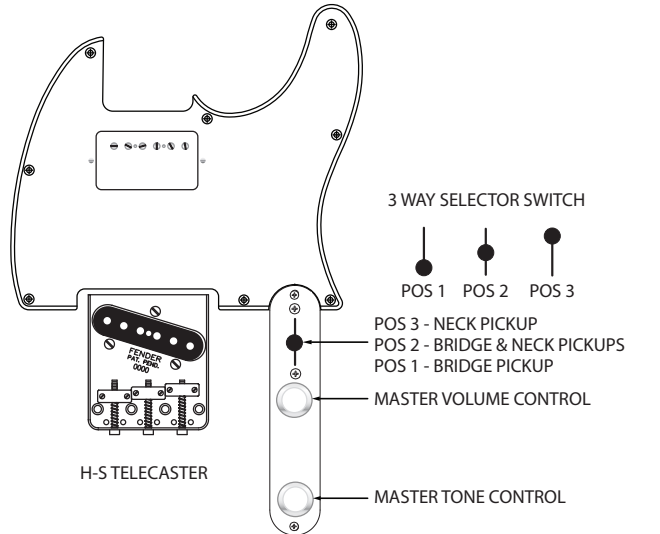
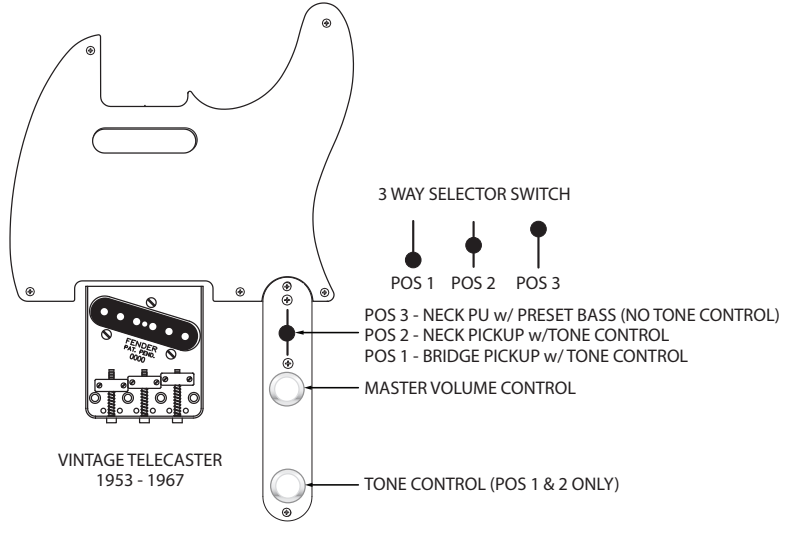
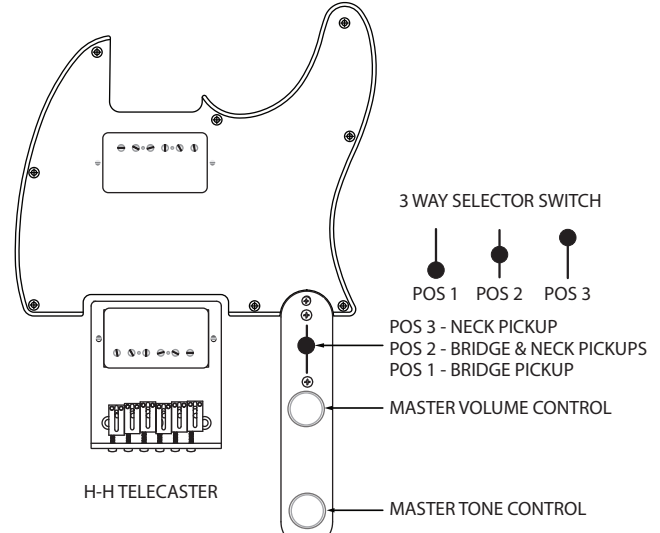
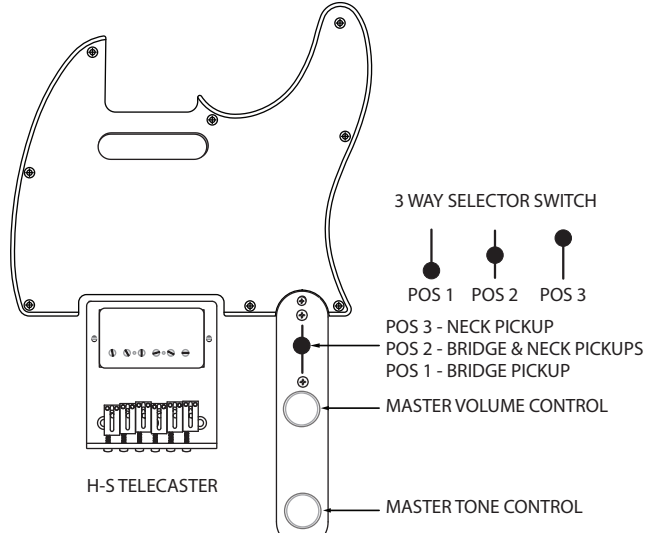
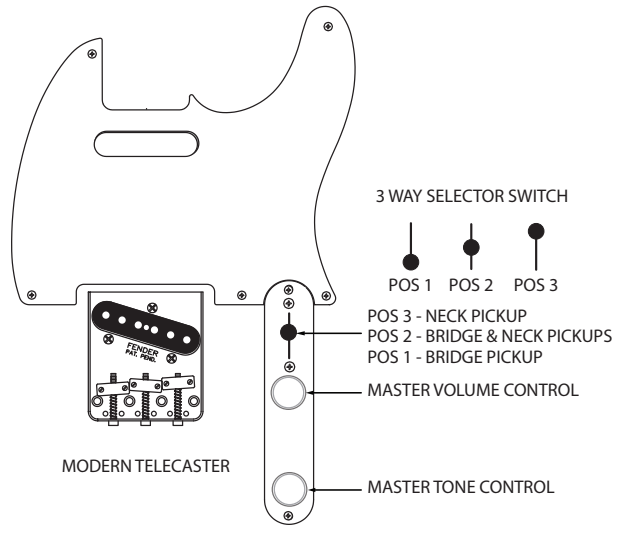
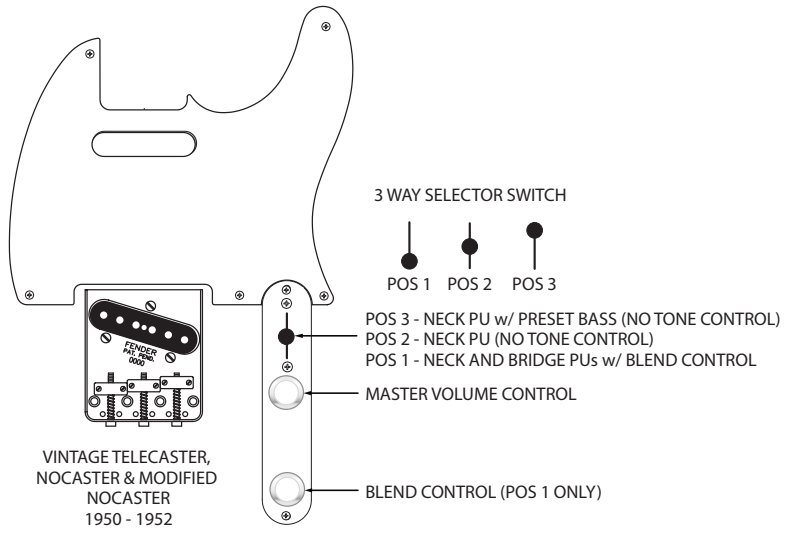

PRECISION BASS WIRING

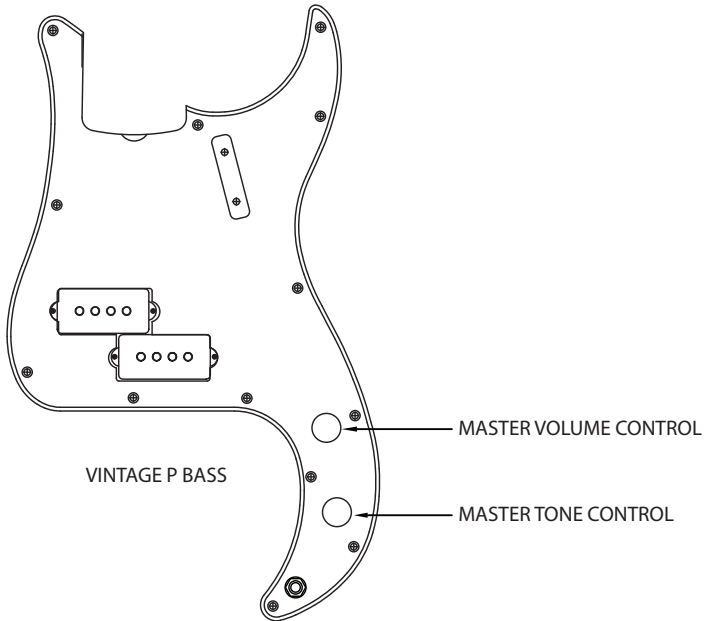

JAZZ BASS WIRING

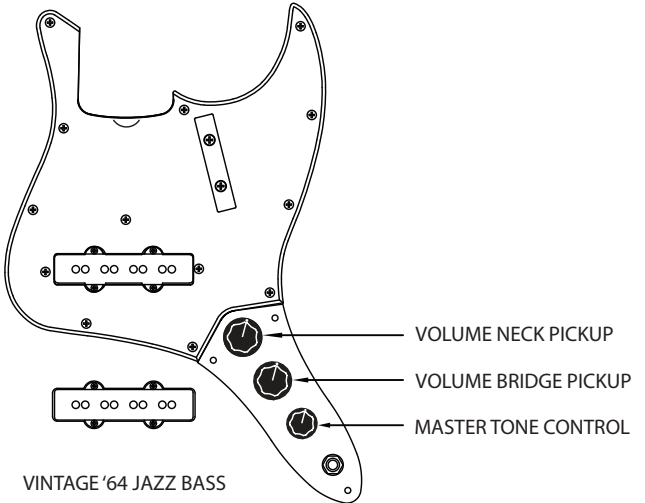
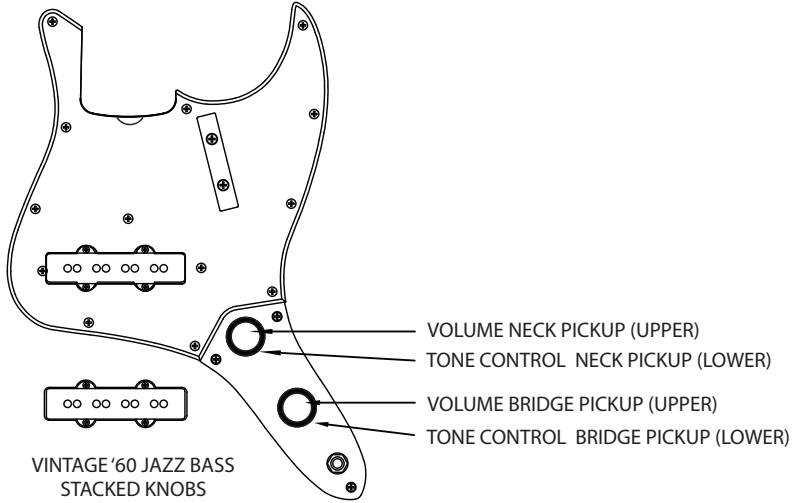

SELECT
HARDWARE OPTIONS

STRATOCASTER BRIDGES

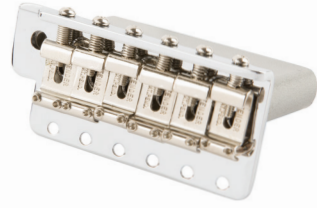

VINTAGE SYNCHRONIZED TREMOLO

Original Stratocaster tremolo made using original die-cast moulds and punch presses.

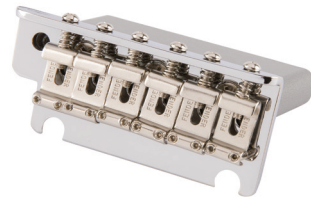

2-POINT CLASSIC PLAYER TREMOLO

Polished steel two-point synchronized tremolo bridge assembly.



2-POINT CUSTOM CLASSIC TREMOLO

Polished steel two-point synchronized tremolo bridge assembly with polished-steel block saddles.

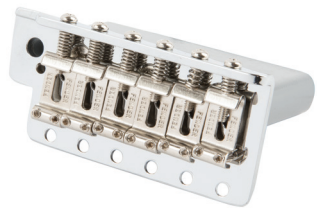

RSD STRAT TREMOLO

Vintage style with improved pivot geometry, plating tolerances, string spacing and arm tension adjustment.

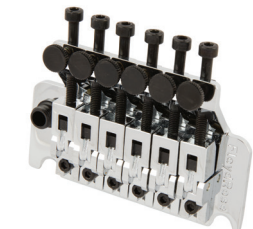

FLOYD ROSE® ORIGINAL

Double-locking tremolo bridge, recessed for pick hand comfort providing laser-accurate intonation and ultra-stable tuning when combined with the Floyd Rose R3 locking nut.

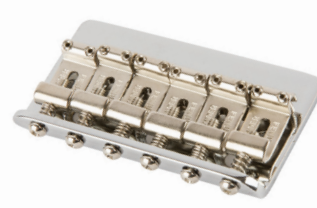

VINTAGE HARD-TAIL

Original hard-tail Strat bridge made using original die cast moulds and punch presses.

TELECASTER BRIDGES

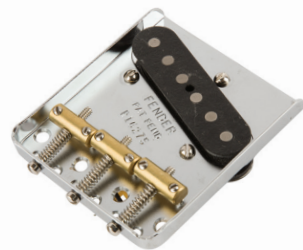

'51-'53 TELECASTER - BRASS SADDLES

Telecaster ashtray bridge plate with original tooling marks, serial number and 3 brass saddles.

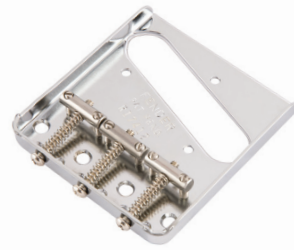

'54-'57 TELECASTER - STEEL SADDLES

Period correct ashtray bridge plate and steel barrel saddles for bright Tele® twang.

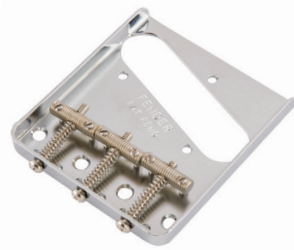

'60 & UP TELECASTER THREADED SADDLES

Period correct ashtray bridge plate and threaded steel saddles for bright Tele® twang.

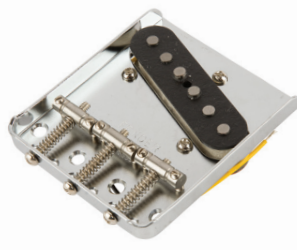

'67 TELE-SLOTTED STEEL SADDLES

Vintage style ashtray bridge plate with notched steel saddles.



RSD TELE

Low profile bridge plate, compensated brass saddles with refined look and feel.

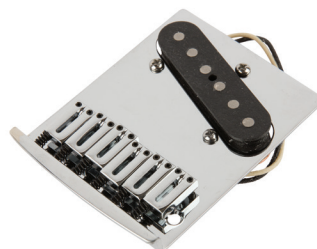

CUSTOM DELUXE TELE

Modern six-saddle bridge assembly with string-through-body plate, and polished steel saddles.

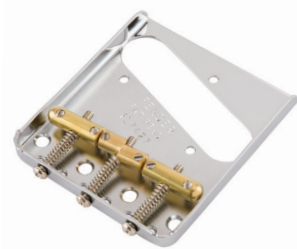

VINTAGE RSD TELE

Vintage style ashtray bridge plate with compensated RSD Saddles.

BASS BRIDGES

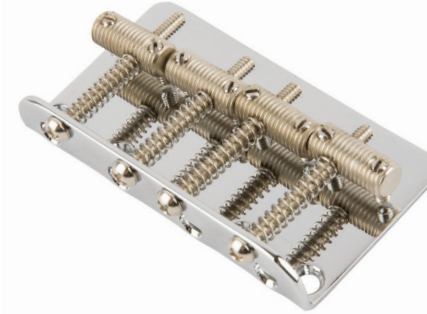

VINTAGE THREADED SADDLES

Genuine Fender bass bridge assembly with nickel-plated steel bridge plate and four threaded barrel saddles.

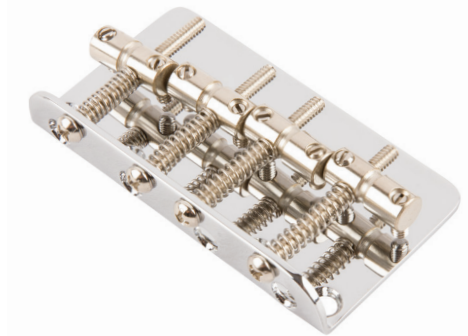

VINTAGE GROOVE SADDLES

Vintage Fender bass bridge assembly with nickel-plated steel bridge plate and four grooved barrel saddles.

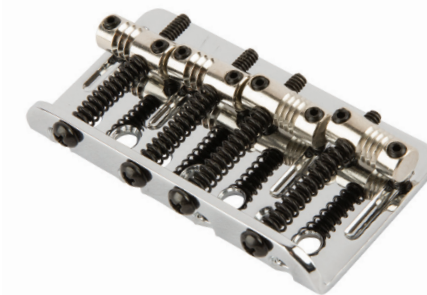

MODERN BASS BRIDGE

Chrome plated steel bridge plate with partially threaded stainless steel saddles and string through body or top load option.



RSD BASS

Hi-Mass Bridge constructed from a solid brass billet with threaded steel saddles.

JAZZMASTER/JAGUAR BRIDGES



RSD J-BRIDGE

Two movable brass saddles bolted to a cold rolled steel base provides an articulate tone with more punch, attack and continuity than its predecessor. The J-Bridge lets the sound of the guitar ring through and gives a stronger primary note.

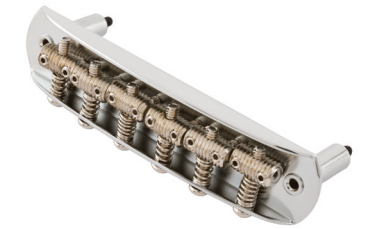

VINTAGE JAZZ/JAG

Nickel-plated bridge assembly with 6 adjustable threaded saddles.

TUNING MACHINES



SCHALLER F



MODERN AMERICAN STANDARD



MODERN LOCKING



VINTAGE LOCKING



VINTAGE

PICKGUARDS



3-PLY WHITE



3-PLY EGGSHELL

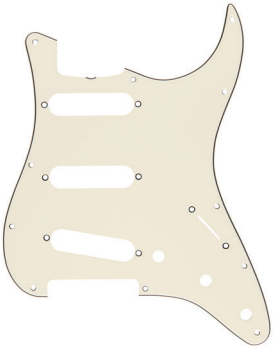

3-PLY PARCHMENT



3-PLY MINT GREEN



ANODIZED GOLD



4-PLY BROWN SHELL



BLACK

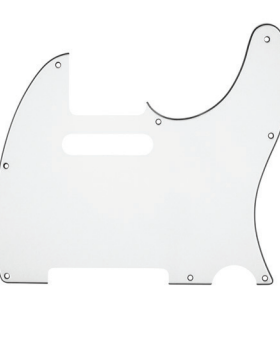

3-PLY WHITE

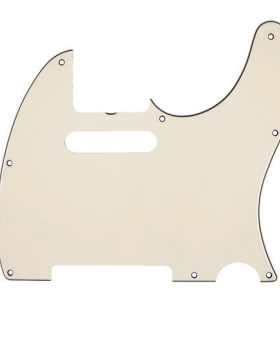

3-PLY PARCHMENT

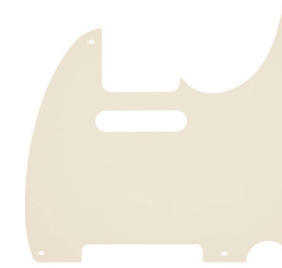

1-PLY PARCHMENT



3-PLY BLACK



BLACK PHENOLIC

SWITCH TIPS, CONTROL KNOBS, AND PICKUP COVERS

SWITCH TIPS



WHITE



EGGSHELL



AGED WHITE



VINTAGE WHITE



BLACK

CONTROL KNOBS



WHITE



EGGSHELL



AGED WHITE



VINTAGE WHITE



BLACK

PICKUP COVERS



WHITE

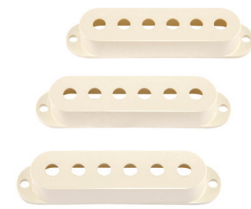

EGGSHELL

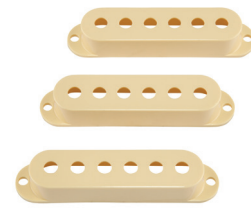

AGED WHITE



VINTAGE WHITE



BLACK

DESIGN GUIDE ORDER FORM

BUILD LEVEL (SELECT ONE)

- MASTERBUILT
SELECT BUILDER _____
- ADD PREMIUM BUILDER
- CUSTOM-BUILT

BASE MODEL

STRATOCASTER (START AT PG 16)

- 1955 STRATOCASTER (ASH)
- 1956 STRATOCASTER (ALDER)
- OTHER 1950'S STRATOCASTER (ALDER) _____
- 1960 STRATOCASTER (ALDER)
- 1963 STRATOCASTER (ALDER)
- 1965 STRATOCASTER (ALDER)
- 1966 STRATOCASTER (ALDER/LARGE HEADSTOCK)
- 1969 STRATOCASTER (ALDER/LARGE HEADSTOCK)
- OTHER 1960'S STRATOCASTER (ALDER) _____
- ELITE STRATOCASTER (ALDER)
- ANVIL FLIGHT CASE OPTION (STRAT)

NOCASTER/TELECASTER/ESQUIRE (START AT PG 18)

- 1951 NOCASTER (ASH)
- 1952 TELECASTER (ASH)
- OTHER 1950'S TELECASTER (ASH) _____
- 1960 TELECASTER (ALDER)
- 1960 TELECASTER CUSTOM (ALDER)
- 1963 TELECASTER (ALDER)
- 1967 TELECASTER (ALDER)
- OTHER 1960'S TELECASTER (ALDER) _____
- 1959 ESQUIRE (ASH)
- OTHER YEAR ESQUIRE _____ (THRU '69)
- THINLINE TELECASTER
- ELITE TELECASTER (ASH)
- ANVIL FLIGHT CASE OPTION (TELE)

JAZZMASTER/JAGUAR/BASS VI (START AT PG 22)

- 1962 JAZZMASTER (ALDER)
- OTHER YEAR JAZZMASTER (ALDER) _____ (THRU '66)
- 1962 JAGUAR (ASH)
- OTHER YEAR JAGUAR (ALDER) _____ (THRU '65)
- BASS VI (ALDER)

FENDER BASS (START AT PG 20)

- 1955 PRECISION BASS (ASH)
- 1959 PRECISION BASS (ALDER)
- 1960 PRECISION BASS (ALDER)
- OTHER YEAR PRECISION BASS (ALDER) _____ (THRU '69)
- 1964 JAZZ BASS (ALDER)
- 1975 JAZZ BASS (ALDER)
- OTHER YEAR JAZZ BASS _____ (THRU '74)

AGING STYLE (START AT PG 24)

- NOS (NEW OLD STOCK)
- TIME CAPSULE (FLASH-COAT NOS/CC HDW)
- CLOSET CLASSIC
- CLOSET CLASSIC/NOS HDW
- DLX CLOSET CLASSIC
- JOURNEYMAN RELIC®
- JOURNEYMAN RELIC/CLOSET CLASSIC HDW
- RELIC
- RELIC/CLOSET CLASSIC HDW
- HEAVY RELIC
- HEAVY RELIC/CLOSET CLASSIC HDW

CUSTOM OPTIONS

CONSTRUCTION

- LEFT HANDED
- CHAMBERED BODY
- HOLLOW BODY W/ F-HOLE (WITH ARM CONTOUR)
- BOUND BODY TOP (NO ARM CONTOUR)
- BOUND BODY TOP & BACK (NO CONTOURS)
- BOUND FINGERBOARD
- BOUND HEADSTOCK
- REVERSE HEADSTOCK
- CONTOURED NECK HEEL
- REVERSE ANGLE BRIDGE PICKUP ROUT

BODY WOOD

- BASE MODEL BODY WOOD
- ALDER
- ASH
- EASTERN WHITE PINE
- OKOUME
- FIJI MAHOGANY
- ROASTED ALDER
- ROASTED ASH
- ROASTED PINE
- SORT FOR LIGHT WEIGHT BODY WOOD
- OTHER BODY WOOD

BODY COLOR (SELECT FROM PAGE 32)

- SINGLE COLOR # _____
- COLOR OVER COLOR # _____ O # _____
- SPARKLE COLOR
- PINK PAISLEY (TOP)
- PINK PAISLEY (TOP & BACK)
- BLACK PAISLEY (TOP)
- BLACK PAISLEY (TOP & BACK)
- BLUE FLOWER (TOP)
- BLUE FLOWER (TOP & BACK)

BODY FINISH

- BASE MODEL FINISH
- NITRO LACQUER
- NITRO LACQUER / WLS UNDERCOAT
- FLASH COAT LACQUER
- URETHANE

*For base model specifications see page 17

CUSTOM OPTIONS (CONTINUED)**NECK WOOD**

- BASE MODEL NECK WOOD (FLAT SAWN MAPLE)
- RIFT SAWN MAPLE
- QUARTERSAWN MAPLE
- FLAME MAPLE 2A
- FLAME QUARTERSAWN MAPLE 2A
- FLAME MAPLE 3A
- BIRDSEYE MAPLE 2A
- BIRDSEYE MAPLE 3A
- ROASTED RIFT SAWN MAPLE
- ROASTED QUARTERSAWN MAPLE
- ROASTED FLAME MAPLE 3A
- OTHER NECK WOOD _____

NECK TINT

- NO TINT
- LIGHT TINT
- MEDIUM TINT
- DARK TINT

NECK FINISH

- BASE MODEL FINISH
- NITRO LACQUER
- FLASH COAT LACQUER
- URETHANE
- SATIN URETHANE
- MATCHING PAINTED HEADCAP

NECK SHAPE

- BASE MODEL NECK SHAPE*
- CUSTOM NECK SHAPE # _____ (START AT PAGE 35)

FINGERBOARD WOOD

- BASE MODEL FINGERBOARD WOOD
- 1-PIECE MAPLE NECK
- ROUND-LAM MAPLE
- SLAB ROSEWOOD
- ROUND-LAM ROSEWOOD
- SORT FOR DARK ROSEWOOD
- AFRICAN BLACKWOOD
- EBONY

FINGERBOARD RADIUS

- BASE MODEL FINGERBOARD RADIUS
- 7.25" RADIUS
- 9.5" RADIUS
- 12.00" RADIUS
- 7.25" TO 9.5" VINTAGE COMPOUND RADIUS
- 7.25" TO 12" COMPOUND RADIUS
- 9.5" TO 12" COMPOUND RADIUS
- 9.5" TO 14" COMPOUND RADIUS
- 9.5" TO 16" COMPOUND RADIUS (BASS ONLY)
- SCALLOPED FINGERBOARD

WIDTH AT NUT

- BASE MODEL WIDTH AT NUT
- 1.650"
- 1.685"
- 1.6875"

NUT MATERIAL

- BASE MODEL NUT MATERIAL
- MICARTA
- BONE
- GRAPHITE
- LSR ROLLERNUT

NUMBER OF FRETS

- BASE MODEL NUMBER OF FRETS
- 22 FRETS (STRAT/TELE)

FRET WIRE

- BASE MODEL FRET WIRE
- VINTAGE
- MEDIUM VINTAGE 47095
- NARROW TALL 6105
- MEDIUM JUMBO 6150
- JUMBO 6100
- OTHER FRET WIRE _____

POSITION & SIDE MARKERS

- BASE MODEL DOT MATERIAL
- BLACK
- WHITE
- VINTAGE CLAY
- MOP WHITE
- BLACK POLY PEARL BLOCK INLAY
- WHITE POLY PEARL BLOCK INLAY
- WHITE MOP BLOCK INLAY

12TH FRET DOT SPACING

- BASE MODEL DOT SPACING
- WIDE 12TH FRET DOT SPACING
- NARROW 12TH FRET DOT SPACING

TRUSS ROD

- BASE MODEL TRUSS ROD
- BI-FLEX™ (STRAT/TELE HEADSTOCK ADJUST)

HARDWARE COLOR

- BASE MODEL HARDWARE COLOR (NICKEL/CHROME)
- GOLD

NECK PLATE

- BASE MODEL NECK PLATE (R SERIAL)
- V-LOGO NECK PLATE
- F-LOGO NECK PLATE
- F-LOGO NECK PLATE (CONTOURED HEEL)

*For base model specifications see page 17

BRIDGE

- BASE MODEL BRIDGE

STRATOCASTER BRIDGE

- AM VINTAGE SYNCHRONIZED TREMOLO
- CUSTOM SHOP VINTAGE STRAT TREMOLO
- 2-POINT CLASSIC PLAYER TREMOLO
- 2-POINT CUSTOM CLASSIC TREMOLO
- RSD STRAT TREMOLO
- VINTAGE HARD-TAIL
- CUSTOM CLASSIC HARD-TAIL
- FLOYD ROSE® DOUBLE LOCKING

TELECASTER BRIDGE

- '51 - '53 TELE - BRASS SADDLES
- '54 - '57 TELE - STEEL SADDLES
- '58 - '63 TELE - THREADED SADDLES
- '64 - '66 TELE - THREADED SADDLES
- '67 TELE - SLOTTED STEEL SADDLES
- CUSTOM DELUXE TELE BRIDGE
- RSD TELE BRIDGE
- RSD HARDTAIL (SAWED OFF TELE)
- BIGSBY® B-5 VIBRATO TAILPIECE

PRECISION/JAZZ BASS

- VINTAGE 2-SADDLE BRIDGE
- VINTAGE THREADED SADDLES BRIDGE
- VINTAGE GROOVE SADDLES BRIDGE
- MODERN BASS BRIDGE
- RSD BASS BRIDGE

JAZZMASTER/JAGUAR

- RSD J-BRIDGE

TUNING MACHINES

- BASE MODEL TUNING MACHINES
- VINTAGE STYLE
- VINTAGE STAGGERED
- VINTAGE LOCKING
- SPERZEL DELUXE
- SPERZEL DELUXE W/ PEARL BUTTONS
- SPERZEL TRIM-LOK™
- FENDER/SCHALLER "F"
- OTHER _____

PICKGUARD

- BASE MODEL PICKGUARD
- 1-PLY WHITE
- 1-PLY EGGSHELL
- 1-PLY PARCHMENT
- 1-PLY BLACK
- 1-PLY BLACK PHENOLIC LAMINATE
- 3-PLY WHITE
- 3-PLY EGGSHELL
- 3-PLY PARCHMENT
- 3-PLY MINT GREEN
- 3-PLY BLACK
- 4-PLY BROWN SHELL
- ANODIZED GOLD
- OTHER _____

*For base model specifications see page 17

CONTROL KNOBS

- BASE MODEL CONTROL KNOBS

STRATOCASTER KNOBS

- WHITE
- EGGSHELL
- PARCHMENT
- VINTAGE WHITE
- BLACK

TELECASTER/PRECISION BASS KNOBS

- VINTAGE KNURLED
- ALUMINUM KNURLED

STRATOCASTER PICKUP COVERS

- BASE MODEL COVERS
- WHITE
- EGGSHELL WHITE
- PARCHMENT WHITE
- VINTAGE WHITE
- BLACK
- LIPSTICK COVERS (EACH)

WIRING

- BASE MODEL WIRING

STRATOCASTER WIRING

- VINTAGE STRAT
- MODERN STRAT
- VINTAGE MODIFIED #1
- VINTAGE MODIFIED #2 W/ TONE-SAVER
- STRAT BLENDER
- STRAT BLENDER W/ GREASEBUCKET
- FAT 50'S HOOKUP
- FAT 50'S HOOKUP W/ HALF BLENDER
- FAT 50'S HOOKUP W/ GREASEBUCKET
- H-S-S POMO STRAT 250/500
- H-S-S CONFIGURATION
- H-S-H CONFIGURATION
- H-H CONFIGURATION
- OTHER STRAT WIRING _____

TELECASTER/ESQUIRE WIRING

- VINTAGE ESQUIRE (1-PICKUP)
- FULL THROTTLE ESQUIRE (1-PICKUP)
- '51 NOCASTER ('50-'52 BLACKGUARD)
- '51 MODIFIED NOCASTER
- '53-'59 VINTAGE TELE
- MODERN TELE
- MODERN TELE W/ GREASEBUCKET
- MODERN TELE W/ 4-WAY SWITCH
- FAT '50S TELE
- NASHVILLE TELE (3-PICKUP TELE)
- H-S TELE DUAL-STACK 250/500
- H-S TELE CABALLO 250/500
- H-H TELE
- OTHER TELE WIRING _____
- FULL THROTTLE ESQUIRE (1-PICKUP)

JAZZ BASS® WIRING

- VINTAGE JAZZ BASS W/ CONCENTRIC KNOBS

MISCELLANEOUS ELECTRONICS

- 3-WAY SWITCH (STRAT)
- REVERSE TELE CONTROL PLATE
- TONE-SAVER TREBLE BLEED
- GREASEBUCKET TONE CONTROL
- TBX TONE CONTROL
- NO-LOAD TONE CONTROL
- S-1 SWITCH
- S-1 FUNCTION _____

PICKUPS

PICKUPS	N	M	B
BASE MODEL PICKUPS*	<input type="checkbox"/>	<input type="checkbox"/>	<input type="checkbox"/>
RWRP MIDDLE PICKUP	<input type="checkbox"/>		
STRATOCASTER PICKUPS (PRICE PER PICKUP)			
'54 STRAT	<input type="checkbox"/>	<input type="checkbox"/>	<input type="checkbox"/>
'50S STRAT	<input type="checkbox"/>	<input type="checkbox"/>	<input type="checkbox"/>
FAT '50S STRAT	<input type="checkbox"/>	<input type="checkbox"/>	<input type="checkbox"/>
'60S STRAT	<input type="checkbox"/>	<input type="checkbox"/>	<input type="checkbox"/>
FAT '60S STRAT	<input type="checkbox"/>	<input type="checkbox"/>	<input type="checkbox"/>
'58 STRAT	<input type="checkbox"/>	<input type="checkbox"/>	<input type="checkbox"/>
'59 STRAT	<input type="checkbox"/>	<input type="checkbox"/>	<input type="checkbox"/>
'65 STRAT	<input type="checkbox"/>	<input type="checkbox"/>	<input type="checkbox"/>
'66 STRAT	<input type="checkbox"/>	<input type="checkbox"/>	<input type="checkbox"/>
'69 STRAT	<input type="checkbox"/>	<input type="checkbox"/>	<input type="checkbox"/>
TEXAS SPECIAL STRAT	<input type="checkbox"/>	<input type="checkbox"/>	<input type="checkbox"/>
HAND-WOUND STRAT® PICKUPS (PRICE PER PICKUP)			
ADD JOSEFINA MASTER WOUND UPGRADE			
HW '50S STRAT	<input type="checkbox"/>	<input type="checkbox"/>	<input type="checkbox"/>
HW FAT '50S STRAT	<input type="checkbox"/>	<input type="checkbox"/>	<input type="checkbox"/>
HW '55 STRAT	<input type="checkbox"/>	<input type="checkbox"/>	<input type="checkbox"/>
HW '56 STRAT	<input type="checkbox"/>	<input type="checkbox"/>	<input type="checkbox"/>
HW '57 STRAT	<input type="checkbox"/>	<input type="checkbox"/>	<input type="checkbox"/>
HW '59 STRAT	<input type="checkbox"/>	<input type="checkbox"/>	<input type="checkbox"/>
HW '60 STRAT	<input type="checkbox"/>	<input type="checkbox"/>	<input type="checkbox"/>
HW FAT '60 STRAT	<input type="checkbox"/>	<input type="checkbox"/>	<input type="checkbox"/>
HW '60/'63 STRAT	<input type="checkbox"/>	<input type="checkbox"/>	<input type="checkbox"/>
HW '64 STRAT	<input type="checkbox"/>	<input type="checkbox"/>	<input type="checkbox"/>
HW '65 STRAT	<input type="checkbox"/>	<input type="checkbox"/>	<input type="checkbox"/>
HW '66 STRAT	<input type="checkbox"/>	<input type="checkbox"/>	<input type="checkbox"/>
HW '69 STRAT	<input type="checkbox"/>	<input type="checkbox"/>	<input type="checkbox"/>
HW TEXAS SPECIAL STRAT	<input type="checkbox"/>	<input type="checkbox"/>	<input type="checkbox"/>
HW TROPOSPHERE™ STRAT	<input type="checkbox"/>	<input type="checkbox"/>	<input type="checkbox"/>
HW MASTER DESIGN LTD STRAT	<input type="checkbox"/>	<input type="checkbox"/>	<input type="checkbox"/>
HW MASTER DESIGN BONE TONE	<input type="checkbox"/>	<input type="checkbox"/>	<input type="checkbox"/>

HW DUAL-MAG STRAT	<input type="checkbox"/>	<input type="checkbox"/>	<input type="checkbox"/>
HW DUAL-MAG II STRAT	<input type="checkbox"/>	<input type="checkbox"/>	<input type="checkbox"/>
HW EL DIABLO STRAT	<input type="checkbox"/>	<input type="checkbox"/>	<input type="checkbox"/>
HW TOMATILLO STRAT	<input type="checkbox"/>	<input type="checkbox"/>	<input type="checkbox"/>
HW ANCHO POBLANO STRAT	<input type="checkbox"/>	<input type="checkbox"/>	<input type="checkbox"/>
OTHER STRAT PICKUPS			
FENDER LACE SENSOR	<input type="checkbox"/>	<input type="checkbox"/>	<input type="checkbox"/>
FENDER VINTAGE NOISELESS	<input type="checkbox"/>	<input type="checkbox"/>	<input type="checkbox"/>
DUNCAN® SLDS-1 HOT RAILS™	<input type="checkbox"/>	<input type="checkbox"/>	<input type="checkbox"/>
DUNCAN SSL-3 HOT STRAT	<input type="checkbox"/>	<input type="checkbox"/>	<input type="checkbox"/>
DUNCAN LI'L SCREAMIN' DEMON™	<input type="checkbox"/>	<input type="checkbox"/>	<input type="checkbox"/>
DUNCAN SLS-1 LIPSTICK TUBE	<input type="checkbox"/>	<input type="checkbox"/>	<input type="checkbox"/>
TELECASTER PICKUPS (PRICE PER PICKUP)			
ORIGINAL BLACKGUARD TELE (OBG)	-	-	<input type="checkbox"/>
'51 TELECASTER/NOCASTER	<input type="checkbox"/>	-	<input type="checkbox"/>
'56/'57 TELE	<input type="checkbox"/>	-	<input type="checkbox"/>
'63 TELE	<input type="checkbox"/>	-	<input type="checkbox"/>
'64 TELE	<input type="checkbox"/>	-	<input type="checkbox"/>
'67 TELE	<input type="checkbox"/>	-	<input type="checkbox"/>
TEXAS SPECIAL TELE	<input type="checkbox"/>	-	<input type="checkbox"/>
TWISTED TELE	<input type="checkbox"/>	-	<input type="checkbox"/>
HAND-WOUND TELE® PICKUPS (PRICE PER PICKUP)			
ADD JOSEFINA MASTER WOUND UPGRADE	<input type="checkbox"/>	-	<input type="checkbox"/>
HW ORIGINAL BLACKGUARD (OBG)	-	-	<input type="checkbox"/>
HW '50/'51 BLACKGUARD	<input type="checkbox"/>	-	<input type="checkbox"/>
HW '50/'51 CRUSHED BLACKGUARD	-	-	<input type="checkbox"/>
HW '51 NOCASTER	<input type="checkbox"/>	-	<input type="checkbox"/>
HW '51 LOADED NOCASTER	<input type="checkbox"/>	-	<input type="checkbox"/>
HW '55/'56 TELE	<input type="checkbox"/>	-	<input type="checkbox"/>
HW '58 TELE	<input type="checkbox"/>	-	<input type="checkbox"/>
HW '63 TELE	<input type="checkbox"/>	-	<input type="checkbox"/>
HW '64 TELE	<input type="checkbox"/>	-	<input type="checkbox"/>
HW '67 TELE	<input type="checkbox"/>	-	<input type="checkbox"/>
HW TWISTED TELE	<input type="checkbox"/>	-	<input type="checkbox"/>
HW TEXAS SPECIAL TELE	<input type="checkbox"/>	-	<input type="checkbox"/>
HW RED HOT TELE	<input type="checkbox"/>	-	<input type="checkbox"/>
OTHER TELE PICKUPS			
FENDER VINTAGE NOISELESS	<input type="checkbox"/>	-	<input type="checkbox"/>
DUNCAN FIVE-TWO TELE	<input type="checkbox"/>	-	<input type="checkbox"/>
DUNCAN QUARTER POUND	<input type="checkbox"/>	-	<input type="checkbox"/>
DUNCAN LITTLE '59™	<input type="checkbox"/>	-	<input type="checkbox"/>

*For base model specifications see page 17

HUMBUCKING/P90 PICKUPS	N	M	B
FENDER SHAWBUCKER	<input type="checkbox"/>	-	<input type="checkbox"/>
EVH® WOLFGANG HUMBUCKER	<input type="checkbox"/>		<input type="checkbox"/>
EVH FRANKENSTEIN HUMBUCKER	<input type="checkbox"/>	-	<input type="checkbox"/>
DUNCAN SH-1 59	<input type="checkbox"/>	-	-
DUNCAN SH-55 SETH LOVER	-	-	<input type="checkbox"/>
DUNCAN SH-4 JB BRIDGE	<input type="checkbox"/>		<input type="checkbox"/>
DUNCAN TB-4 TREMBUCKER™	<input type="checkbox"/>	-	<input type="checkbox"/>
DUNCAN SH-PG1 PEARLY GATES™	<input type="checkbox"/>	-	<input type="checkbox"/>
DUNCAN ANTIQUITY HUMBUCKER	<input type="checkbox"/>	-	<input type="checkbox"/>
DUNCAN APH-1 ALNICO II PRO™	<input type="checkbox"/>	-	<input type="checkbox"/>
DUNCAN TBAPH-1 ALNICO II PRO TREMBUCKER	<input type="checkbox"/>	-	<input type="checkbox"/>
DUNCAN SCREAMIN' DEMON	<input type="checkbox"/>	-	<input type="checkbox"/>
DUNCAN SH-8 INVADER	<input type="checkbox"/>	-	<input type="checkbox"/>
TV JONES® CLASSIC (TELE ONLY)	<input type="checkbox"/>	-	<input type="checkbox"/>
TV JONES CLASSIC PLUS (TELE ONLY)	<input type="checkbox"/>	-	<input type="checkbox"/>
TV JONES POWER 'TRON (TELE ONLY)	<input type="checkbox"/>	-	<input type="checkbox"/>
TV JONES POWER 'TRON PLUS (TELE ONLY)	<input type="checkbox"/>	-	<input type="checkbox"/>
TV JONES SUPER 'TRON (TELE ONLY)	<input type="checkbox"/>	-	<input type="checkbox"/>
TV JONES MAGNA 'TRON (TELE ONLY)	<input type="checkbox"/>	-	<input type="checkbox"/>
P-90	<input type="checkbox"/>	-	<input type="checkbox"/>

*For base model specifications see page 17

BASS PICKUPS	N	M	B
PRECISION BASS PICKUPS			
'55 PRECISION BASS	-	<input type="checkbox"/>	-
'57 PRECISION BASS	-	<input type="checkbox"/>	-
'59 – '62 PRECISION BASS	-	<input type="checkbox"/>	-
'59 – '62 PRECISION BASS (FLAT POLES)	-	<input type="checkbox"/>	-
HW '55 PRECISION BASS	-	<input type="checkbox"/>	-
HW '57 PRECISION BASS	-	<input type="checkbox"/>	-
HW '62 PRECISION BASS	-	<input type="checkbox"/>	-
JAZZ BASS PICKUPS			
'60S JAZZ BASS	<input type="checkbox"/>	-	<input type="checkbox"/>
'75 JAZZ BASS	<input type="checkbox"/>	-	<input type="checkbox"/>
CUSTOM CLASSIC JAZZ BASS	<input type="checkbox"/>	-	<input type="checkbox"/>
HW '60S JAZZ BASS	<input type="checkbox"/>	-	<input type="checkbox"/>
HW '75 JAZZ BASS	<input type="checkbox"/>	-	<input type="checkbox"/>
JAZZMASTER/JAGUAR/BASS VI PICKUPS			
VINTAGE JAZZMASTER	<input type="checkbox"/>	-	<input type="checkbox"/>
HW VINTAGE JAZZMASTER	<input type="checkbox"/>	-	<input type="checkbox"/>
VINTAGE JAGUAR/BASS VI	<input type="checkbox"/>	-	<input type="checkbox"/>



For Design Guide orders,
please use: PN# 7721933000

1964 JAZZ BASS® - JOURNEYMAN RELIC®
SUPER FADED AGED TAHITIAN CORAL - 9237100904